



SMARTEH[®]
LIVING SYSTEMS

USER MANUAL

- Longo Bluetooth Products
LBT-1.DO4
Bluetooth Mesh Triac output
module

Version 2

Written by SMARTEH d.o.o.
Copyright © 2023, SMARTEH d.o.o.

User Manual

Document Version: 2
May 2023



STANDARDS AND PROVISIONS: Standards, recommendations, regulations and provisions of the country in which the devices will operate, must be considered while planning and setting up electrical devices. Work on 100 .. 240 V AC network is allowed for authorized personnel only.

DANGER WARNINGS: Devices or modules must be protected from moisture, dirt and damage during transport, storing and operation.

WARRANTY CONDITIONS: For all modules LBT-1 - if no modifications are performed upon and are correctly connected by authorized personnel - in consideration of maximum allowed connecting power, warranty of 24 months is valid from the date of sale to the end buyer, but not more than 36 months after delivery from Smarteh. In case of claims within warranty time, which are based on material malfunctions the producer offers free replacement. The method of return of malfunctioned module, together with description, can be arranged with our authorized representative. Warranty does not include damage due to transport or because of unconsidered corresponding regulations of the country, where the module is installed.



This device must be connected properly by the provided connection scheme in this manual. Misconnections may result in device damage, fire or personal injury.



Hazardous voltage in the device can cause electric shock and may result in personal injury or death.

NEVER SERVICE THIS PRODUCT YOURSELF!

This device must not be installed in the systems critical for life (e.g. medical devices, aircrafts, etc.).



If the device is used in a manner not specified by the manufacturer, the degree of protection provided by the equipment may be impaired.

Waste electrical and electronic equipment (WEEE) must be collected separately!

LBT-1 devices are developed considering the following standards:

- EMC: EN 303 446-1
- LVD: EN 60669-2-1

Smarteh d.o.o. operates a policy of continuous development. Therefore we reserve the right to make changes and improvements to any of the products described in this manual without any prior notice.

MANUFACTURER:

SMARTTEH d.o.o.
 Poljubinj 114
 5220 Tolmin
 Slovenia



Index

Longo Bluetooth Products LBT-1.D04

- 1.ABBREVIATIONS.....1
- 2.DESRIPTION.....2
- 3.FEATURES.....3
- 4.OPERATION.....4
 - 4.1.Other triac output module functions.....5
 - 4.2.Operation parameters.....6
- 5.INSTALLATION.....9
 - 5.1.Connection scheme.....9
 - 5.2.Mounting instructions.....11
- 6.SYSTEM OPERATION14
 - 6.1.Interference warning14
- 7.TECHNICAL SPECIFICATIONS.....15
- 8.MODULE LABELING.....16
- 9.CHANGES17
- 10.NOTES.....18





1. ABBREVIATIONS

LED	Light Emitted Diode
PLC	Programmable Logic Controller
PC	Personal Computer
OpCode	Message Option Code



2. DESCRIPTION

LBT-1.DO4 Bluetooth Mesh two triac output module is designed to be used as a shades or curtains motor control module with RMS current and voltage measuring possibility. The module can operate with a wide range of AC voltages. It can be placed inside the 60mm diameter flush mounting box. It can also be placed close to shades or curtains motor. Switch input is provided to have the possibility of manually switching On and Off the two triac outputs. This input can detect 50/60 HZ for triac 1 control and 25/30 HZ for triac 2 control. Two positions push button switch with an appropriate diode as 1N4007 should be connected to the switch input line wire as shown in Figure 4. Only one triac output, triac output 1 or triac output 2, can operate at the time.

LBT-1.DO4 Bluetooth Mesh two triac output module can only operate with Smarteh LBT-1.GWx Modbus RTU Bluetooth Mesh gateway connected to the same Bluetooth Mesh network. LBT-1.GWx Modbus RTU gateway is connected to the main control device as Smarteh LPC-3.GOT.012 7" PLC based Touch panel, any other PLC or any PC with Modbus RTU communication. Besides Smarteh Bluetooth Mesh devices, other standard Bluetooth Mesh devices can be integrated into above mentioned Bluetooth Mesh network. More than a hundred Bluetooth Mesh devices can be provisioned and can operate in a single Bluetooth Mesh network.



3. FEATURES

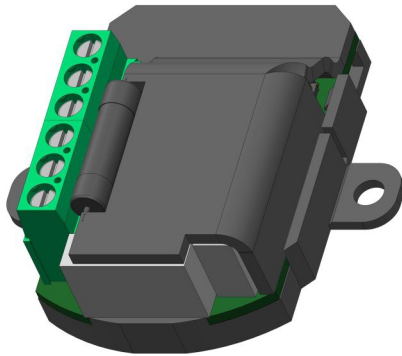

Figure 1: LBT-1.DO4

Table 1: Technical data

Communication standard: Bluetooth Mesh is a low power wireless mesh protocol and allows device to device communication and device to main control device communication.

Radio frequency: 2.4 GHz

Radio range for direct connection: < 30 m, depending on application and building.
By using Bluetooth Mesh topology, much bigger distances can be achieved.

Power supply: 90 .. 264 V AC

Ambient temperature: 0 .. 40 °C

Storage temperature: -20 .. 60 °C

Status indicators: red and green LED

2 x Triac output, 0.7 A continuous per output/ 1 A pulsing per output

RMS current and voltage measurement, power consumption measurement

Switch digital input

Mounting in flush mounting box



4. OPERATION

LBT-1.DO4 Bluetooth Mesh Triac output module can only operate with Smarteh LBT-1.GWx Modbus RTU Bluetooth Mesh gateway while provisioned to the same Bluetooth Mesh network.

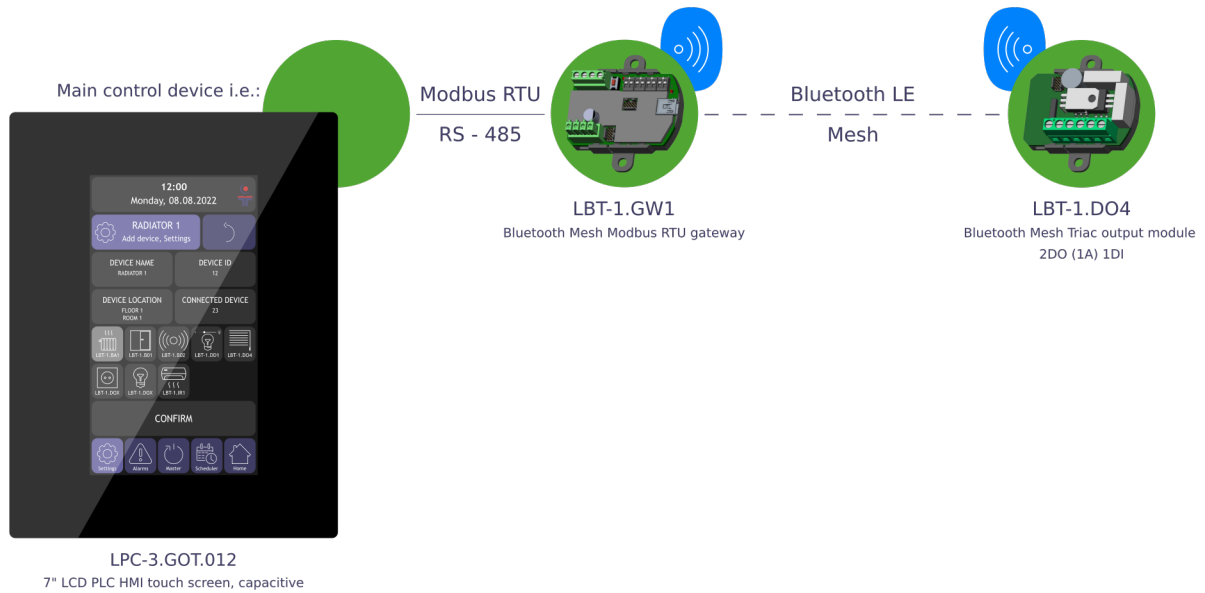

Figure 2: LBT-1.DO4 device connection

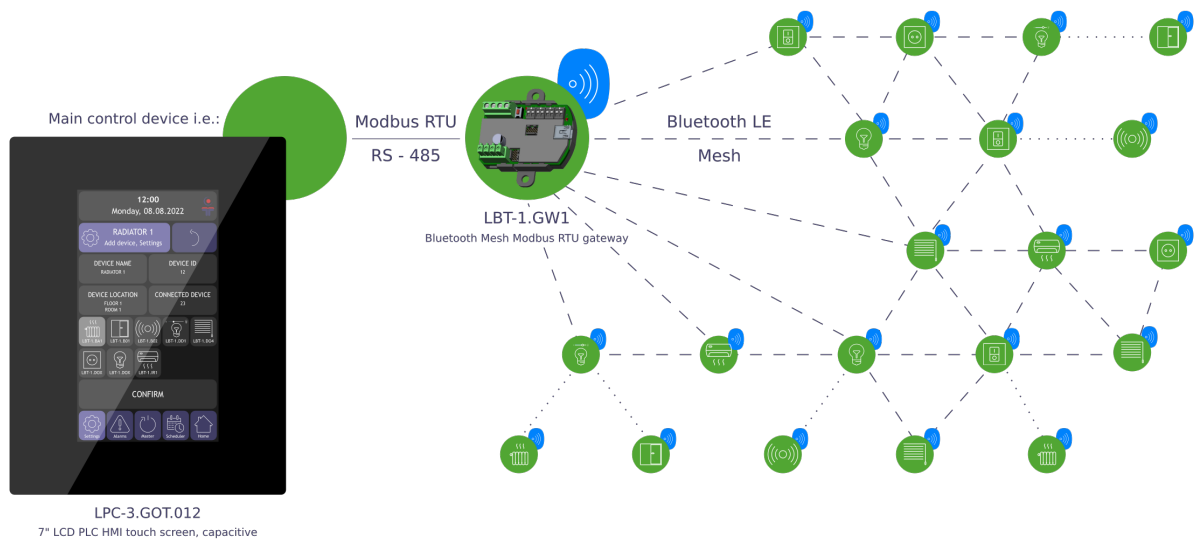

Figure 3: Bluetooth Mesh system topology



4.1. Other triac output module functions

- **Factory reset:** This function will delete all Bluetooth Mesh network parameters stored on LBT-1.DO4 triac output module and will restore to the conditions of the initial programming, ready for provisioning. See Table 5 for more information.



4.2. Operation parameters

LBT-1.DO4 Bluetooth Mesh Triac output module accepts a set of operation codes as specified in below tables 2 to 4.

LBT-1.DO4 Bluetooth Mesh output module is communicating with main control device as Smarteh LPC-3.GOT.012 via Smarteh LBT-1.GWx Modbus RTU Bluetooth Mesh gateway.

All communication between main control device as LPC-3.GOT.012 or similar is performed by using Modbus RTU communication. Individual Bluetooth Mesh node configuration data should be observed by using network provisioning tool.

Table 2: 4xxxx, Holding registers, Modbus RTU to Bluetooth Mesh gateway

Reg.	Name	Description	Raw → Engineering data
10	Execute command	Execute command for Read and/or Write by toggling bit	Bit0 toggle → Write Bit1 toggle → Read
11	Destination address*	Destination node address. Can be a unicast, group or virtual address	0 .. 65535 → 0 .. 65535
12	Element index*	Sending node model element index	0 .. 65535 → 0 .. 65535
13	Vendor ID*	Vendor ID of the sending node model	0 .. 65535 → 0 .. 65535
14	Model ID*	Model ID of the sending node model	0 .. 65535 → 0 .. 65535
16	Virtual address index*	Index of the destination Label UUID	0 .. 65535 → 0 .. 65535
17	Application key index*	The application key index used	0 .. 65535 → 0 .. 65535
18	Option code**	Refer to the option code table	0 .. 63 → 0 .. 63
19	Payload byte length**	Refer to the option code table	1 .. 10 → 1 .. 10 bytes
20	Payload word[0]**	Refer to the option code table	0 .. 65535 → 0 .. 65535
21	Payload word[1]**	Refer to the option code table	0 .. 65535 → 0 .. 65535
22	Payload word[2]**	Refer to the option code table	0 .. 65535 → 0 .. 65535
23	Payload word[3]**	Refer to the option code table	0 .. 65535 → 0 .. 65535
24	Payload word[4]**	Refer to the option code table	0 .. 65535 → 0 .. 65535

* Observed from network provisioning tool

** User defined parameters, refer to option code table



Table 3: 3xxxx, Input registers, Modbus RTU to Bluetooth Mesh gateway

Reg.	Name	Description	Raw → Engineering data
10	Messages pending	Number of messages pending in receiving buffer	1 .. 10 → 1 .. 10
11	Destination address	Destination node address. Can be a unicast, group or virtual address	0 .. 65535 → 0 .. 65535
12	Element index	Sending node model element index	0 .. 65535 → 0 .. 65535
13	Vendor ID	Vendor ID of the sending node model	0 .. 65535 → 0 .. 65535
14	Model ID	Model ID of the sending node model	0 .. 65535 → 0 .. 65535
15	Source address	Unicast address of the node model which sent the message	0 .. 65535 → 0 .. 65535
16	Virtual address index	Index of the destination Label UUID	0 .. 65535 → 0 .. 65535
17	Application key index	The application key index used	0 .. 65535 → 0 .. 65535
18	Option code	Refer to the option code table	0 .. 63 → 0 .. 63
19	Payload length	Refer to the option code table	1 .. 10 → 1 .. 10 bytes
20	Payload word[0]	Refer to the option code table	0 .. 65535 → 0 .. 65535
21	Payload word[1]	Refer to the option code table	0 .. 65535 → 0 .. 65535
22	Payload word[2]	Refer to the option code table	0 .. 65535 → 0 .. 65535
23	Payload word[3]	Refer to the option code table	0 .. 65535 → 0 .. 65535
24	Payload word[4]	Refer to the option code table	0 .. 65535 → 0 .. 65535

Table 4: Triac output LBT-1.DO4 option codes

Option code	Name	Description	Raw → Engineering data
1	FW version status	Firmware version status	0 .. 65535 → 0 .. 65535
2	Operation mode set	Node operation mode selection	0 → Not used 1 → Not used 2 → Not used 3 → Not used 4 → Reset 5 → Factory reset



Table 4: Triac output LBT-1.DO4 option codes

9	Wake up interval command	Command to set the time interval in which the device wakes up and sends data about the current and voltage status	0 .. 65535 → 0 .. 65535 s
10	Wake up interval status	Status of the time interval in which the device wakes up and sends data about the current and voltage status	0 .. 65535 → 0 .. 65535 s
18	Voltage status	Input voltage RMS value	0 .. 65535 → 0 .. 6553.5 V
19	Current status	Load current RMS value	0 .. 65535 → 0 .. 65.535 A
40	Digital Out 1 command	Load output 1 command, L1	0 → OFF 1 → ON
41	Digital Out 1 status	Status of load output 1, L1	0 → OFF 1 → ON
42	Digital Out 2 command	Load output 2 command, L2	0 → OFF 1 → ON
43	Digital Out 2 status	Status of load output 2, L2	0 → OFF 1 → ON
53	Load output 1 switch enable command	Command for enabling switching on the load output 1 on SW input	0 → Disable 1 → Enable
54	Load output 1 switch enable status	Enable status of the SW input for load output 1	0 → Disabled 1 → Enabled
55	Load output 2 switch enable command	Command for enabling switching on the load output 2 on SW input	0 → Disable 1 → Enable
56	Load output 2 switch enable status	Enable status of the SW input for load output 2	0 → Disabled 1 → Enabled



5. INSTALLATION

5.1. Connection scheme

Figure 4: Example of connection scheme

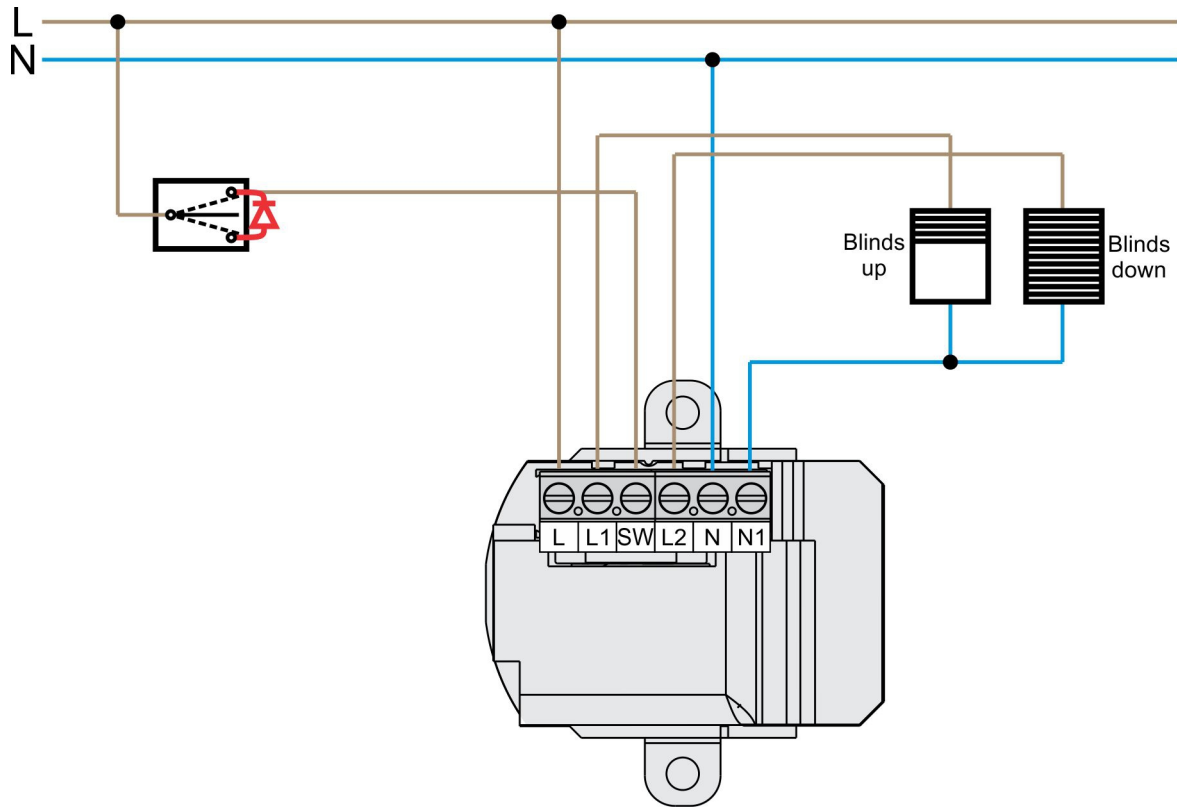

Figure 5: LBT-1.D04 module

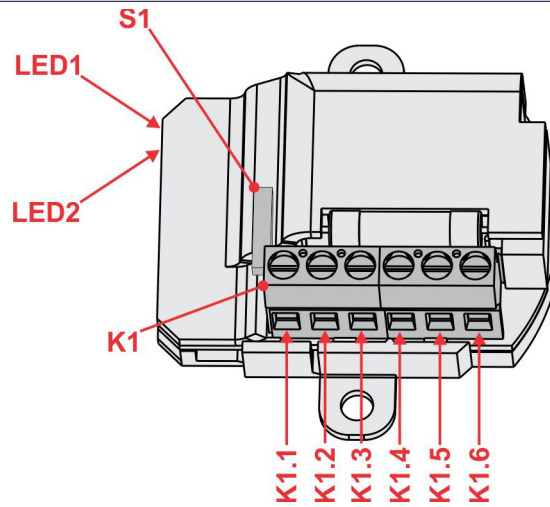

Table 5: Inputs and LEDs

K1.1	N1	Load output: neutral						
K1.2	N	Power supply input: neutral						
K1.3	L2	Load output 2: line						
K1.4	SW	Switch input: line, 90 .. 264 V AC						
K1.5	L1	Load output 1: line						
K1.5	L	Power supply input: line, 90 .. 264 V AC						
LED1: red	Error	2x blink inside 5 s time period = network/friend lost 3x blink inside 5 s time period = unprovisioned node						
LED2: green	Status	1x blink = normal operation. It's also feedback for S1 reed contact, when activated with magnet.						
S1	Reed contact	<p>Mode setting contact</p> <p>Inside 5 s time window, perform corresponding number of swipes in duration of not less than 200 ms with permanent magnet close to the window sensor S1 reed contact position. Following window sensor action or mode will be set:</p> <table border="1"> <thead> <tr> <th>Number of swipes</th> <th>Action</th> </tr> </thead> <tbody> <tr> <td>4</td> <td>Reset</td> </tr> <tr> <td>5</td> <td>Factory reset</td> </tr> </tbody> </table> <p>A hardware reset is triggered if reed contact is continuously closed with a permanent magnet for more than 5 seconds.</p>	Number of swipes	Action	4	Reset	5	Factory reset
Number of swipes	Action							
4	Reset							
5	Factory reset							



5.2. Mounting instructions

Figure 6: Housing dimensions

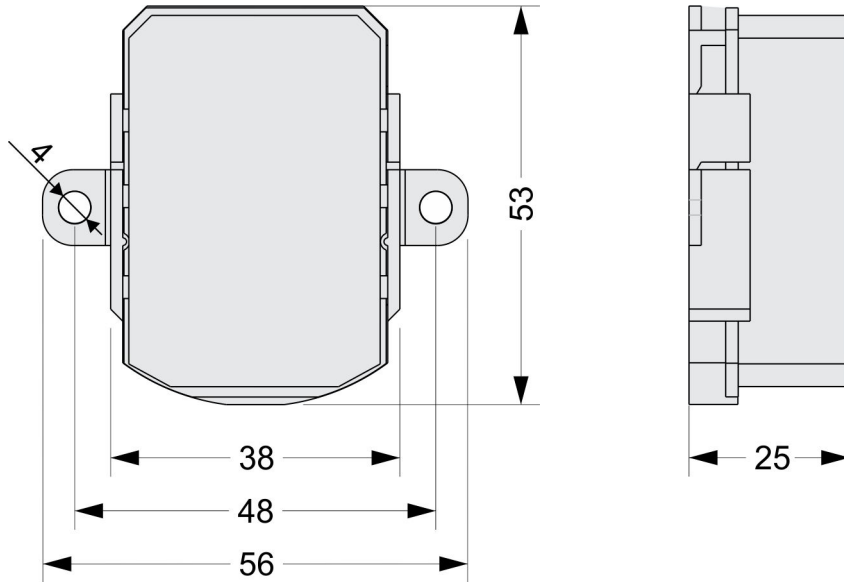

Dimensions in millimeters.

Figure 7: Mounting in flush mounting box

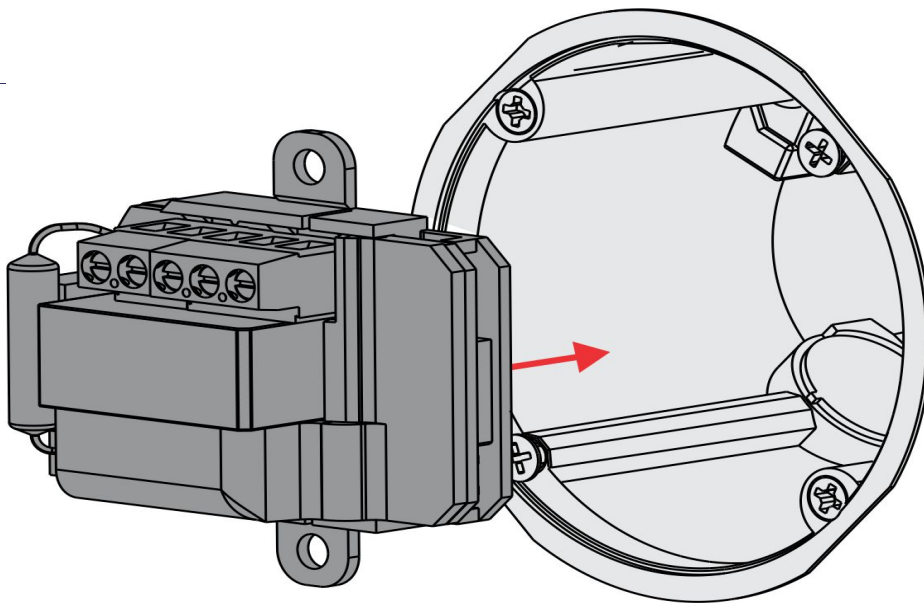

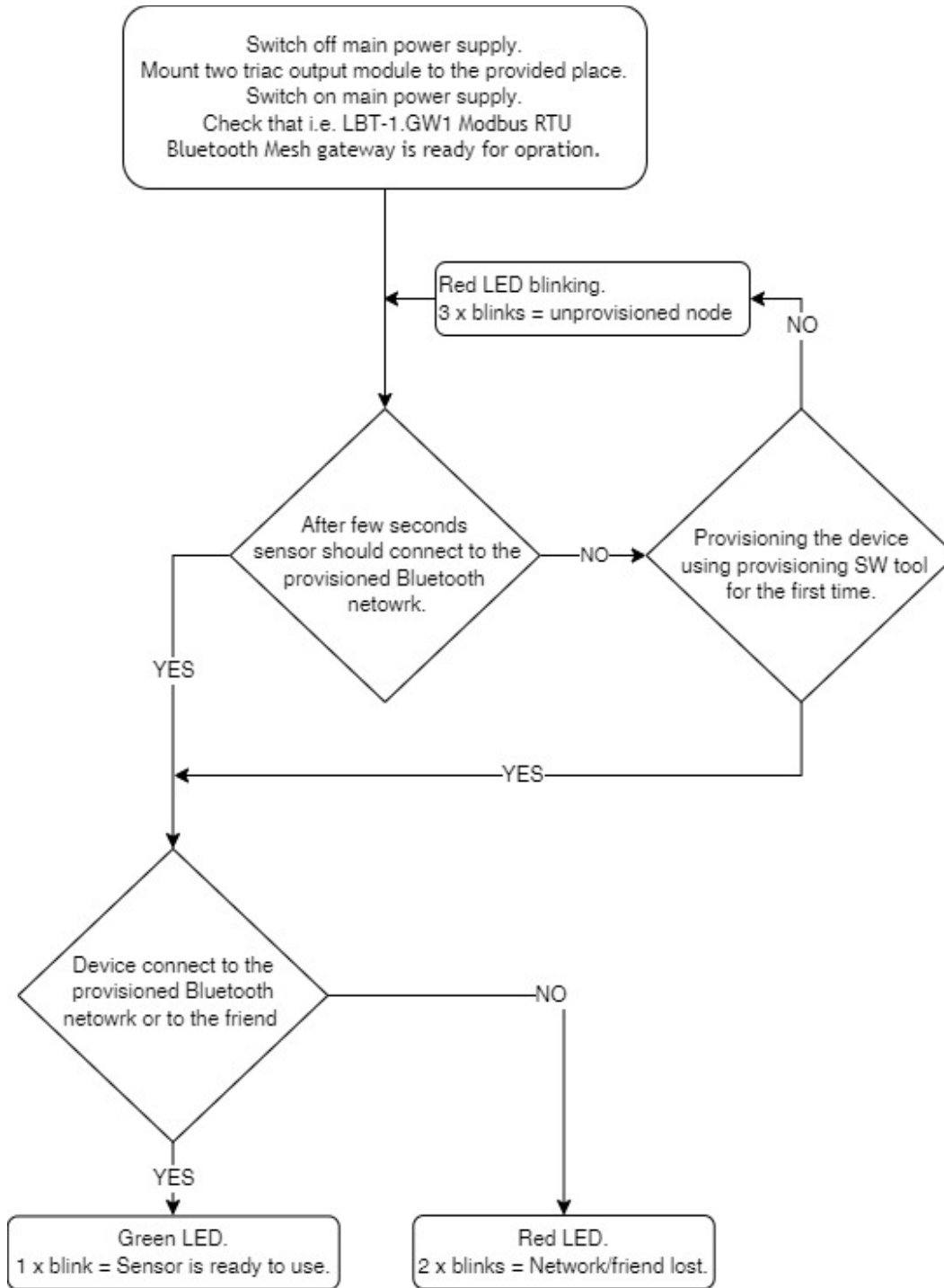

Figure 8: Installation flowchart



1. Switching Off the main power supply.
2. Mount the module up to the provided place and wire the module according to the connection scheme in Figure 4. Two position push button switch and appropriate diode as 1N4007 should be connected to the LBT-1.DO4 module switch input line wire as shown on Figure 4.
3. Switching On the main power supply.
4. After a few seconds Green or Red LED starts to blink, please see the flowchart above for details.
5. If the module is not provisioned Red LED will blink 3x, the provisioning procedure has to be started. Contact the producer for more details*.
6. Once provisioning is finished, the module will continue with the normal mode of operation and this will be indicated as Green LED blinking once per 10 seconds.

Dismount in reverse order.

***NOTE:** Smarteh Bluetooth Mesh products are added and connected to a Bluetooth Mesh network by using standard provisioning and configuration mobile apps tool such as nRF Mesh or similar.

Please contact producer for more detail information.



6. SYSTEM OPERATION

LBT-1.DO4 Bluetooth Mesh triac output module can switch power to two triac outputs, usually to power shade or curtain motors, based on 50/60Hz or 25/30Hz voltage present on module switch input or based on Bluetooth Mesh command. Only one triac output can operate at a time.

6.1. Interference warning

Common sources of unwanted interference are devices that generate high frequency signals. These are typically computers, audio and video systems, electronics transformers, power supplies and various ballasts. The distance of the LBT-1.DO4 two triac output module to the above mentioned devices should be at least 0.5m or greater.

WARNING:

- In order to protect plants, systems, machines and network against cyber threats, necessary to implement and continuously maintain up to date security concept.
- You are responsible for preventing unauthorized access to your plants, systems, machines and networks and they are allowed to be connected to Internet only, when security measures like firewalls, network segmentation, ... are in place.
- We strongly recommend the updates and usage of latest version. Usage of version that are no longer supported may increase the possibility of cyber threats.



7. TECHNICAL SPECIFICATIONS

Table 7: Technical specifications

Power supply	90 .. 264 V AC, 50/60 Hz
Max. power consumption	1.5 W
Fuse	1 A (T-slow), 250 V
Load voltage	Same as power supply voltage
Max. continuous load current per output	0.7 A
Max. load current per output, 50% On / 50% Off, pulse <100 s	1 A
Connection type	Screw type connectors for stranded wire 0.75 to 2.5 mm ²
RF communication interval	Minimum 0.5 s
Dimensions (L x W x H)	53 x 38 x 25 mm
Weight	40 g
Ambient temperature	0 to 40 °C
Ambient humidity	Max. 95 %, no condensation
Maximum altitude	2000 m
Mounting position	Any
Transport and storage temperature	-20 to 60 °C
Pollution degree	2
Over voltage category	II
Electrical equipment	Class II (double insulation)
Protection class	IP 10



8. MODULE LABELING

Figure 10: Label

Label (sample):

XXX-N.ZZZ.UUU
P/N: AAABBBCCDDDEEE
S/N: SSS-RR-YYXXXXXXXXXX
D/C: WW/YY

Label description:

1. **XXX-N.ZZZ** - full product name,
 - **XXX-N** - product family,
 - **ZZZ.UUU** - product,
2. **P/N: AAABBBCCDDDEEE** - part number,
 - **AAA** - general code for product family,
 - **BBB** - short product name,
 - **CCDDD** - sequence code,
 - **CC** - year of code opening,
 - **DDD** - derivation code,
 - **EEE** - version code (reserved for future HW and/or SW firmware upgrades),
3. **S/N: SSS-RR-YYXXXXXXXXXX** - serial number,
 - **SSS** - short product name,
 - **RR** - user code (test procedure, e.g. Smarteh person xxx),
 - **YY** - year,
 - **XXXXXXXXXX** - current stack number,
4. **D/C: WW/YY** - date code,
 - **WW** - week and,
 - **YY** - year of production.

Optional:

- **MAC**,
- **Symbols**,
- **WAMP**,
- **Other**.





9. CHANGES

The following table describes all the changes to the document.

Date	V.	Description
25.05.23	2	Reviewed text, fuse specifications.
05.05.23	1	The initial version, issued as <i>LBT-1.DO4 relay output module UserManual</i> .





10. NOTES

