



SMARTEH[®]
LIVING SYSTEMS

USER MANUAL

- ▶ Longo programmable controller
LPC-3.GOT.111
Graphical Operation Terminal

Version 9

Written by SMARTEH d.o.o.
Copyright © 2021, SMARTEH d.o.o.

User Manual

Document Version: 9
November, 2021



STANDARDS AND PROVISIONS: Standards, recommendations, regulations and provisions of the country in which the devices will operate, must be considered while planning and setting up electrical devices. Work on 100 .. 230 V AC network is allowed for authorized personnel only.

DANGER WARNINGS: Devices or modules must be protected from moisture, dirt and damage during transport, storing and operation.

WARRANTY CONDITIONS: For all modules LONGO LPC-3 - if no modifications are performed upon and are correctly connected by authorized personnel - in consideration of maximum allowed connecting power, warranty of 24 months is valid from the date of sale to the end buyer, but not more than 36 months after delivery from Smarteh. In case of claims within warranty time, which are based on material malfunctions the producer offers free replacement. The method of return of malfunctioned module, together with description, can be arranged with our authorized representative. Warranty does not include damage due to transport or because of unconsidered corresponding regulations of the country, where the module is installed.

This device must be connected properly by the provided connection scheme in this manual. Misconnections may result in device damage, fire or personal injury.

Hazardous voltage in the device can cause electric shock and may result in personal injury or death.

NEVER SERVICE THIS PRODUCT YOURSELF!

This device must not be installed in the systems critical for life (e.g. medical devices, aircrafts, etc.).

If the device is used in a manner not specified by the manufacturer, the degree of protection provided by the equipment may be impaired.

Waste electrical and electronic equipment (WEEE) must be collected separately!

LONGO LPC-3 complies to the following standards:

- EMC: EN 61000-6-3:2007 + A1:2011, EN 61000-6-1:2007, EN 61000-3-2:2006 + A1:2009 + A2: 2009, EN 61000-3-3:2013,
- LVD: IEC 61010-1:2010 (3rd Ed.), IEC 61010-2-201:2013 (1st Ed.)

Smarteh d.o.o. operates a policy of continuous development. Therefore we reserve the right to make changes and improvements to any of the products described in this manual without any prior notice.

MANUFACTURER:

SMARTEH d.o.o.
 Poljubinj 114
 5220 Tolmin
 Slovenia



Index

Longo programmable controller LPC-3.GOT.111

- 1 ABBREVIATIONS.....1
- 2 DESCRIPTION.....2
- 3 FEATURES.....3
- 4 OPERATION.....4
 - 4.1 Parameters.....4
- 5 INSTALLATION.....5
 - 5.1 Block diagram.....5
 - 5.2 Input & output connection interfaces.....6
 - 5.3 Mounting instructions.....8
 - 5.4 Example of power supply from main module and CAN communication.....11
- 6 TECHNICAL SPECIFICATIONS.....12
- 7 GROUNDING POSSIBILITIES.....13
 - 7.1 Grounding possibilities.....13
- 8 PROGRAMMING GUIDE.....14
 - 8.1 Basic functionalities.....14
 - 8.2 GUI design and programming.....17
- 9 MODULE LABELING.....18
- 10 SPARE PARTS.....19
- 11 CHANGES20
- 12 NOTES.....21



1 ABBREVIATIONS

PLC	Programmable logic controller
GUI	Graphical user interface
TCP	Transmission control protocol
RTU	Remote terminal unit
RTC	Real time clock
IDE	Integrated development environment
FBD	Function block diagram
LD	Ladder diagram
SFC	Sequential function chart
ST	Structured text
IL	Instruction list
CAN	Controller area network
COM	Communication
SD	Secure digital
LED	Light emitting diode
NDEF	NFC data exchange format
UID	Unique identifier
RAM	Random access memory
NV	Non volatile
PS	Power supply



2 DESCRIPTION

SmarteH LPC-3.GOT.111 graphical operation terminal is designed and developed as ideal solution for building automation as a supplement to LPC-2 modules. It is PLC based product with software tools allowing users to design GUI. Different communication protocols offers various connectivity opportunities. Frameless glass screen offers an intuitive, clear and flexible interface between the user and the building.

LPC-3.GOT.111 is equipped with Ethernet connection and can be used as a Modbus TCP/IP Master and/or Slave device or BACnet IP (B-ASC). USB port is used for local programming and debugging. Over TCP/IP, programming and debugging is possible via LAN (inside building) or even via WAN network (remotely over internet).

LPC-3.GOT.111 also includes two CAN bus for CANopen protocol and RS-485 bus for Modbus RTU master protocol, used e.g. for local or remote connection to other LPC PLCs. Integrated "Setting Storage FLASH", "RTC" and "NV RAM", does not need the battery for it is functioning. There is also a built-in buzzer which can be controlled through PLC program.

LPC-3.GOT.111 has on-board peripherals, such as temperature measurement and ambient light measurement, which gives this terminal extra value and possibilities of use.

SmarteH IDE (Integrated Development Environment) software tool is used with all the PLCs from the LPC family and it supports all five standard PLC programmable languages (FBD, LD, SFC, ST, IL). It also supports "off line", "on line" debugging and local/remote program transferring. Distributed processing is supported which makes it possible to handle fast operations. GUI design tool supports large set of dynamic controls from buttons to indicators and enables connectivity between PLC programs and user interface.

LPC-3.GOT.111 is an innovative and an attractive solution for a competitive price.

LPC-3.GOT.111 is powered from external DC power supply.



3 FEATURES



Figure 1: LPC-3.GOT.111

Table 1: Features

Frameless glass screen with 4.3" LCD display and capacitive touch screen - landscape or portrait orientation

Graphical interface is freely designed by the user with GUI editor in SmartehIDE

Integrated temperature and light sensor

Ethernet connectivity with Modbus TCP/IP Slave (server) and/or Master (client) functionality, BACnet IP (B-ASC), web server and SSL

Modbus RTU Master or Slave

USB port for Debugging and application transfer

Remote access and application transfer

Two CAN ports - one for master, one for slave

RTC and 512 kB NV RAM with super capacitor for needed energy storage

Built-in buzzer controlled from PLC program

Display brightness level controlled from PLC program

Disconnectable connectors

3 status LEDs

Flush mount in various flush mounting boxes or screw mount

Quality design



4 OPERATION

Module parameters can be read or written via Smarteh IDE software.

4.1 Parameters

If parameter is set to logical “1”, is considered to be active, enabled or set. If parameter has logical value “0” is considered to be inactive, disabled or cleared.

Parameters are located in Read channel group. These parameters are received from the On-Board peripherals.

Read channel:

Act. Room temp. [*iTAct*]: Actual room temperature measured by GOT.

Type: WORD

Raw to engineering data: 0 .. 5000 → 0.00 °C .. 50.00 °C

Actual Light intensity [*iLight*]: Ambient light sensitivity

Type: WORD

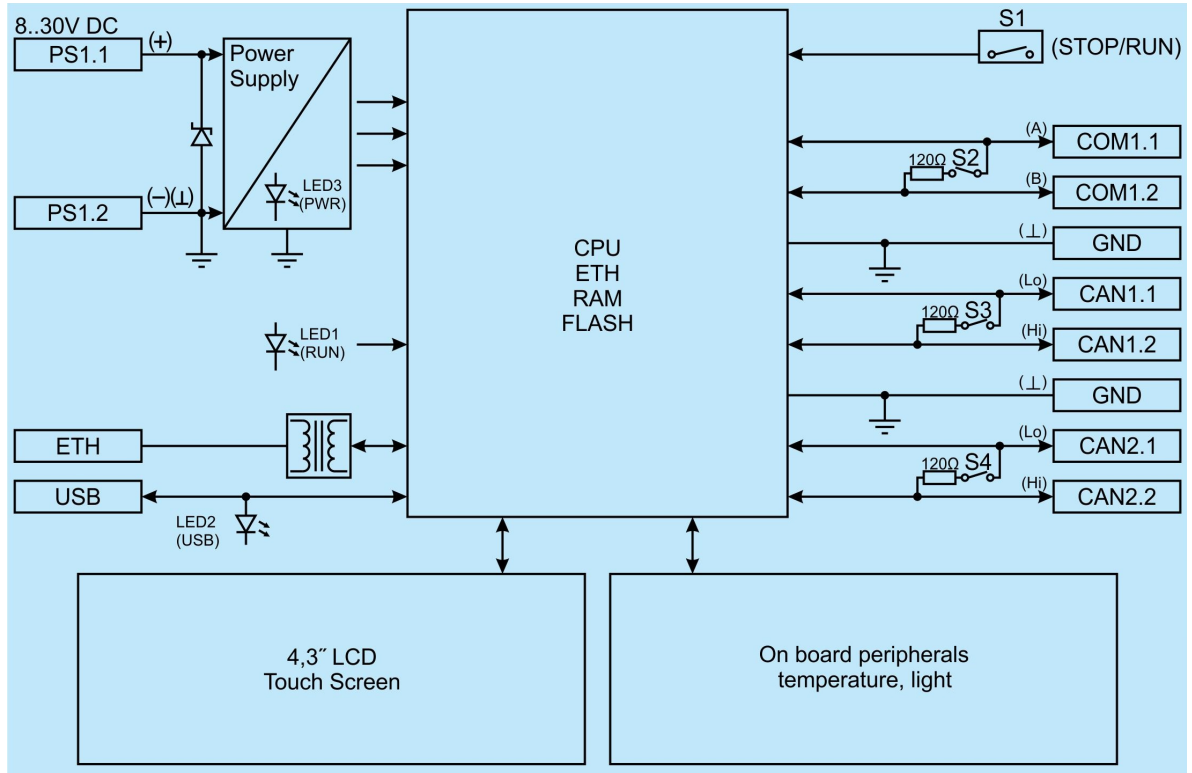
Raw to engineering data: 0 .. 10000 → 0 .. 10000 %



5 INSTALLATION

5.1 Block diagram

Figure 2: Block diagram¹



¹ Coloured areas represents different voltage domains - galvanic isolated areas. Please refer to General technical specifications in TECHNICAL SPECIFICATION for details.



5.2 Input & output connection interfaces

Figure 3: Connection scheme

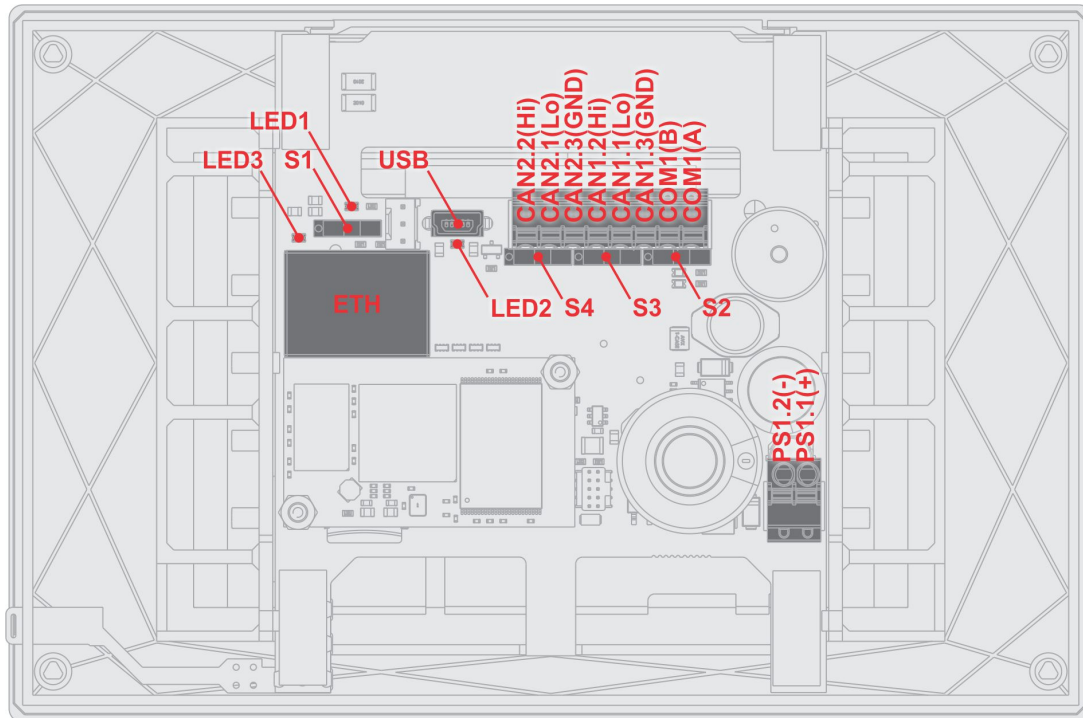


Table 2: Power supply²

PS1.1 (+)	PLC power supply	8 .. 30 V DC, 2 A
PS1.2 (-)	⊥	GND

Table 3: Switches

S1	Operation mode (RUN/STOP)	RUN: PLC normal operational mode STOP: application not running
S2	COM1 RS-485 termination (Trm1)	ON: corresponding channel is internally terminated with 120 Ω OFF: no internal termination present
S3	CAN1 bus termination (Trm2)	ON: corresponding channel is internally terminated with 120 Ω OFF: no internal termination present
S4	CAN2 bus termination (Trm3)	ON: corresponding channel is internally terminated with 120 Ω OFF: no internal termination present

² Wires connected to the module must have cross sectional area at least 0.75 mm². Minimum temperature rating of wire insulation must be 85 °C.



Table 4: CAN1 & CAN2³

CAN1.1	CAN1 Low (Lo) (Master)	0 .. 5 V
CAN1.2	CAN1 High (Hi) (Master)	
GND	⊥	GND
CAN2.1	CAN2 Low (Lo) (Slave)	0 .. 5 V
CAN2.2	CAN2 High (Hi) (Slave)	

Table 5: COM1 RS-485⁴

COM1(A)	RS-485 (A)	0 .. 5 V
COM1(B)	RS-485 (B)	
GND	⊥	GND

Table 6: LEDs

LED1: green	Application running (RUN)	ON: application is running OFF: application is stopped or PLC in boot mode
LED2: blue	Additional LED	Not used
LED3: green	Power (PWR)	ON: PLC is powered on OFF: PLC has no power supply

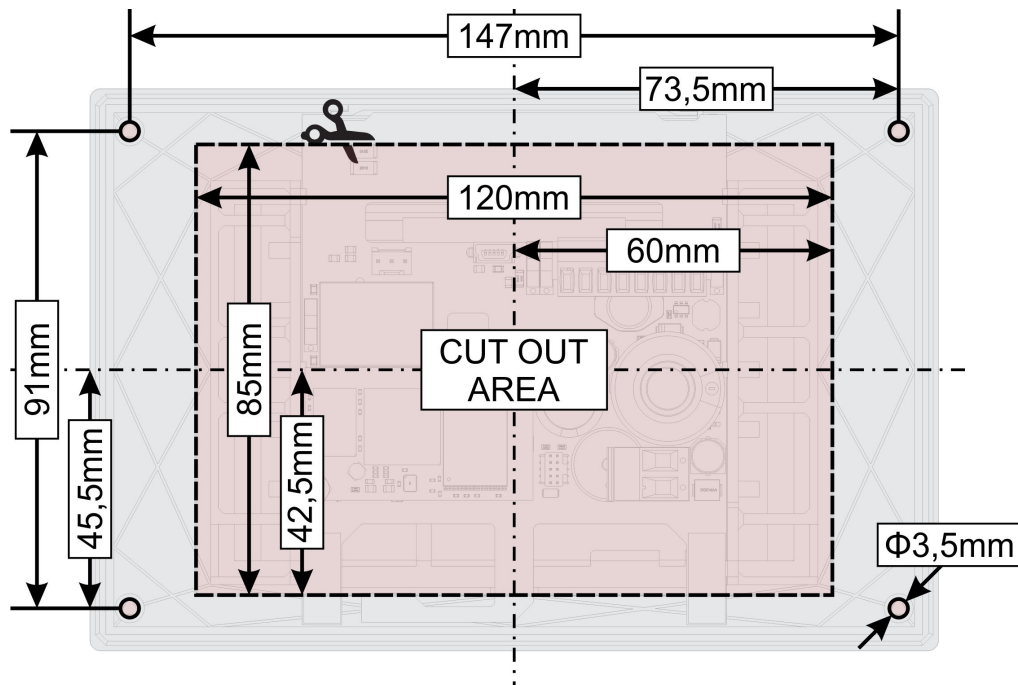
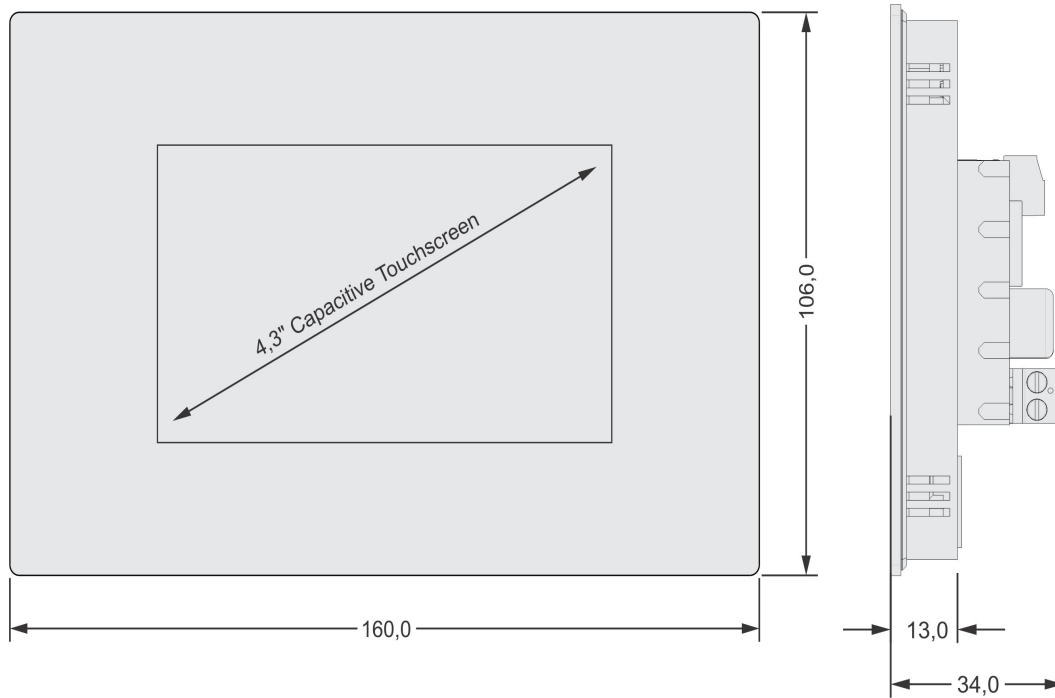
³ **Wires** connected to the module must have cross sectional area at least 0.14 mm². Use twisted-pair cables of type CAT5+ or better, shielding is recommended. Minimum temperature rating of wire insulation must be 85 °C.

⁴ **Different protocols** like Modbus RTU Master can be selected inside Smarteh IDE. **Wires** connected to the module must have cross sectional area at least 0.14 mm². Use twisted-pair cables of type CAT5+ or better, shielding is recommended. Minimum temperature rating of wire insulation must be 85 °C.



5.3 Mounting instructions

Figure 4: Housing dimensions



Dimensions in millimeters.



EXTERNAL SWITCH OR CIRCUIT-BREAKER AND EXTERNAL OVERCURRENT PROTECTION: The unit is allowed to be connected to installation with over current protection that has nominal value of 6 A or less.



All connections, PLC attachments and assembling must be done while LPC-3.GOT.111 is not connected to the main power supply. Module should be positioned in the wall inside of the room. Avoid direct sunlight, positioning near heating/cooling source object or under high luminance lights for best performance of the on-board sensors. Junction box and tubes in the wall must be sealed to prevent airflow. Displayed temperature is adequate to temperature approx. 10 cm below module and 1 cm off the wall. Recommended installation height is 1.5 m above floor level. Portrait orientation of the module may produce slight errors in temperature measurements.

Wires connected to the PLC must have cross sectional area at least 0.75 mm². Minimum temperature rating of wire insulation must be 85 °C.

Mounting instructions:

1. Switch off power supply.
2. Fasten mounting frame⁵ with screws⁵ into TEM VM4 HM40, TEM PM4 DM40, Elettrocanali EC37104, Legrand 801 42 or similar flush mounting box⁶ - see Figure 5.⁷
3. Connect input, output and communication wires.
4. Mount LPC-3.GOT.111 into flush mounting box, using provided springs - see Figure 5.
5. Switch on power supply.

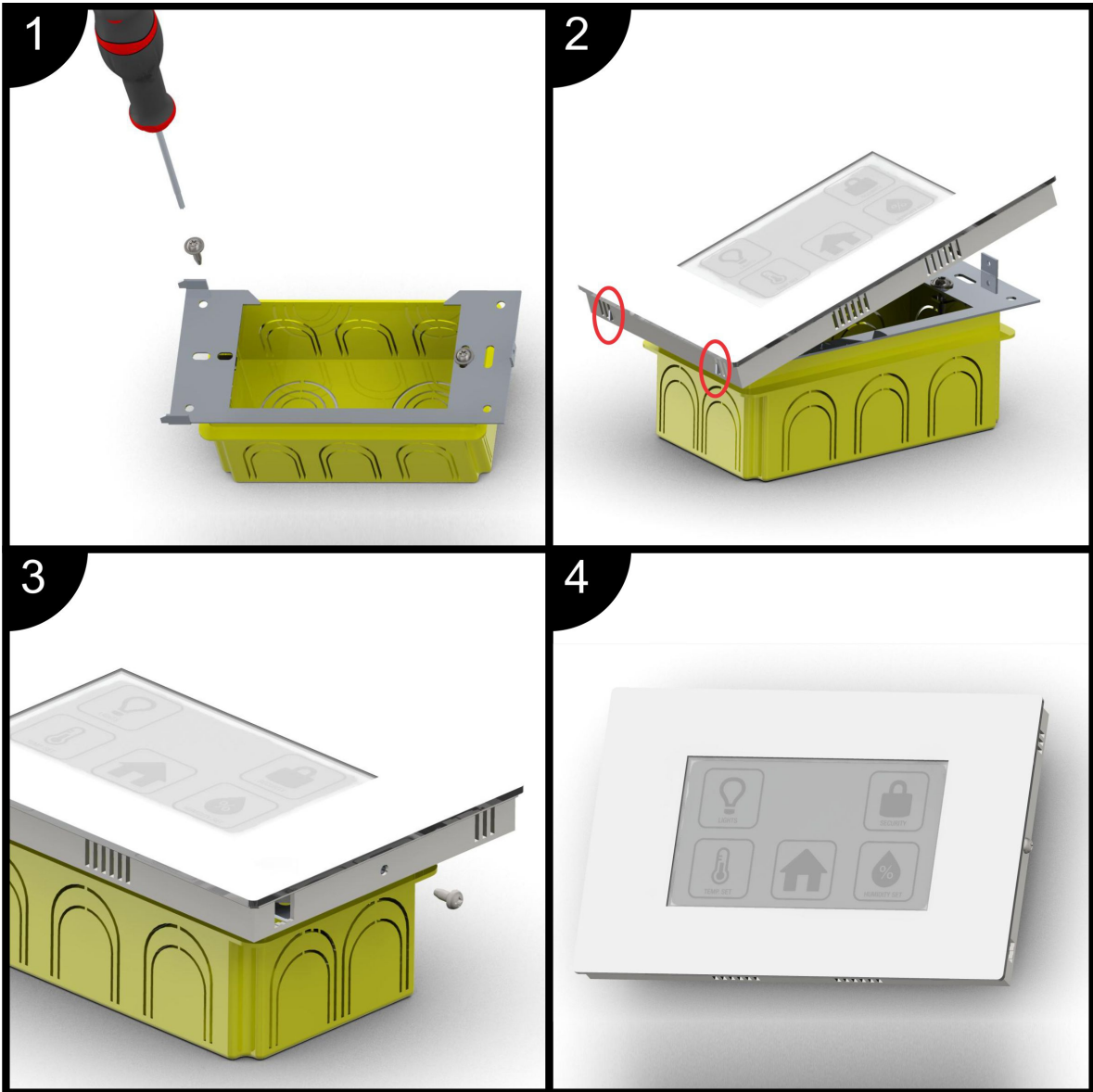
⁵ Mounting frame, screws and springs are provided in package with LPC-3.GOT.111.

⁶ Flush mounting box must be ordered separately - contact Smarteh.

⁷ In case that the bracket touches the walls of the mounting box, it can be folded inwards.

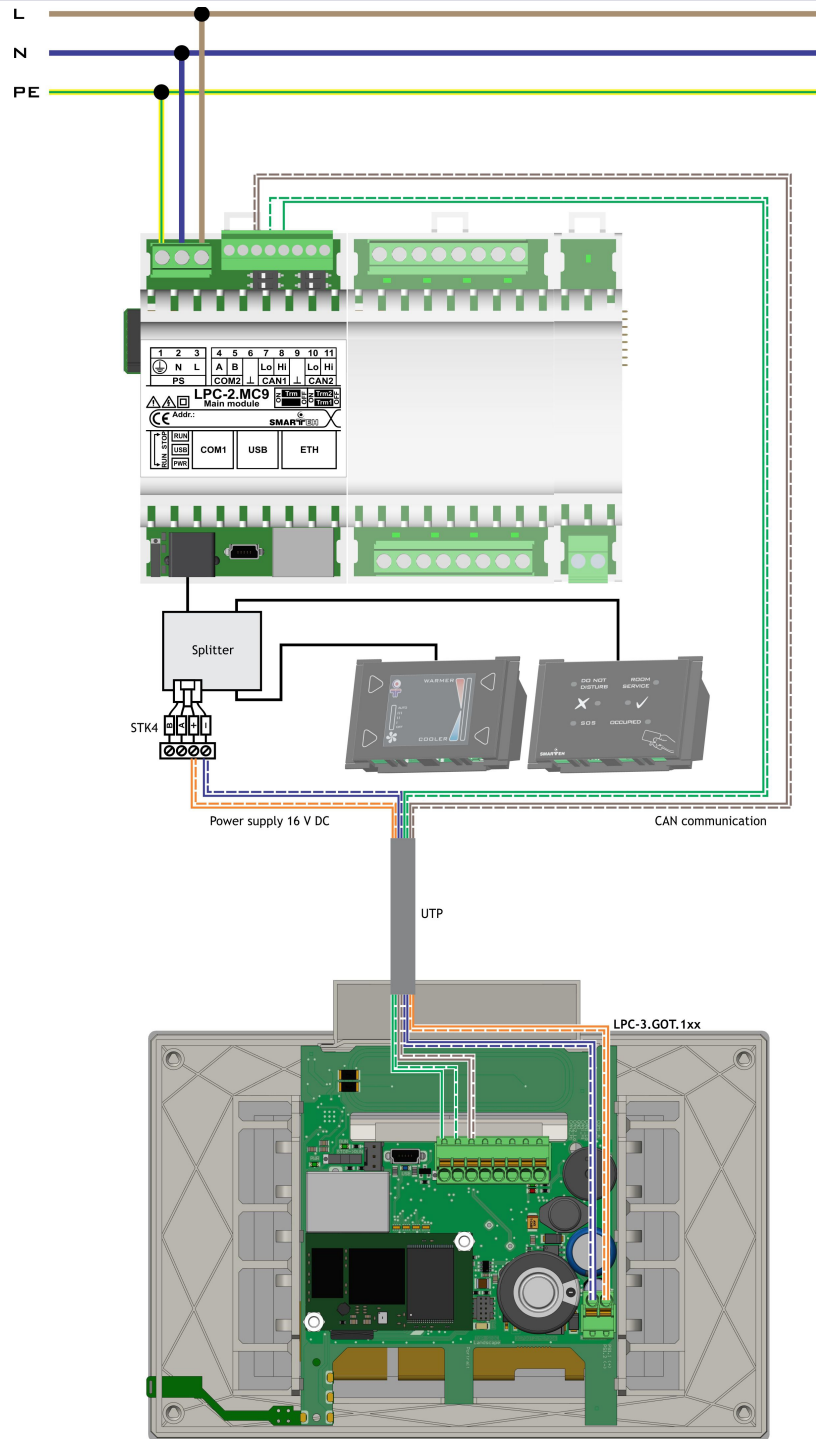


Figure 5: Mounting instructions for flush mount



5.4 Example of power supply from main module and CAN communication

Figure 6: Example of power supply from main module and CAN communication



NOTE: Example connection on Figure 6 loads main module with additional 5 W. Check if power consumption of main module configuration in Smarteh IDE, have additional 5 W available.



6 TECHNICAL SPECIFICATIONS

Table 7: Technical specifications

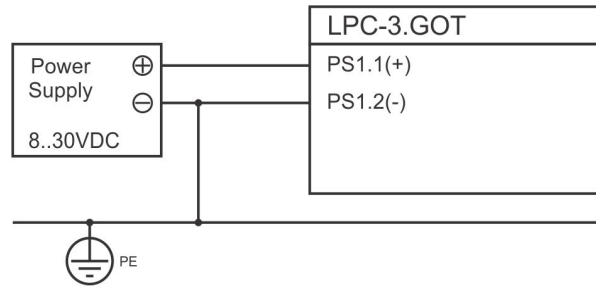
Power supply PS1	8 .. 30 V DC
Inrush current	max. 2 A
Power consumption PS1	max. 5 W
Connection type for PS1	disconnectable screw type connectors for stranded wire 0.75 to 2.5 mm ²
Connection type for CAN1, CAN2, COM1	disconnectable spring type connectors for stranded wire 0.14 to 1.5 mm ²
CAN1 and CAN2	non isolated
COM1 RS-485 port	non isolated, 2 wire
Ethernet	RJ-45 10/100T IEEE 802.3i
USB	mini B type, device mode or host mode (USB On-The-Go), high-speed/full-speed
RTC	capacitor backed up with retention of cca. 14 days
Operating system	Linux
CPU	SOC ARM9 454 MHz
RAM	256 MB DDR2
Flash	512 MB SLC NAND
NV RAM	512 kB, capacitor backed up with retention cca. 14 days
Display	4.3", 480 × 272 resolution
Dimensions (L x W x H)	106 x 160 x 34 mm
Display dimensions (L x W)	54 x 95 mm
Weight	300 g
Ambient temperature	0 to 50 °C
Ambient humidity	max. 95 %, no condensation
Maximum altitude	2000 m
Mounting position	vertical
Transport and storage temperature	-20 to 60 °C
Pollution degree	2
Over-voltage category	II
Electrical equipment	class II (double insulation)



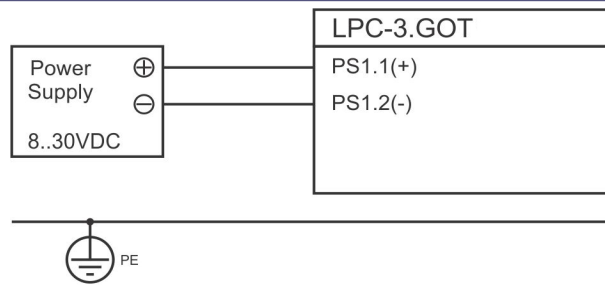
7 GROUNDING POSSIBILITIES

7.1 Grounding possibilities

Figure 7: Grounding possibilities



LPC-3.GOT negative power supply pole connected to the Protective Earth (PE) functional earthing.



LPC-3.GOT negative power supply poles not connected to the Protective Earth (PE) functional earthing.



8 PROGRAMMING GUIDE

This chapter is intended to offer the programmer additional informations about some of the functionalities and units integrated in this module.

8.1 Basic functionalities

RTC unit

For RTC back-up and for Retain variables there is Super Capacitor instead of battery integrated inside PLC. This way, replacement of the discharged battery is avoided. The Retention time is minimum 14 days from the power down. RTC time provides date and time information.

Modbus TCP/IP master unit

When configured for Modbus TCP/IP Master / Client mode, the LPC-3.GOT.111 functions as a master device, controlling the communications with other slave devices such as sensors, inverters, other PLCs, etc. LPC-3.GOT.111 sends Modbus TCP/IP commands to and receives Modbus TCP/IP responses from the slave units.

Following commands are supported:

- 01 - Read Coil Status
- 02 - Read Input Status
- 03 - Read Holding Registers
- 04 - Read Input Registers
- 05 - Write Single Coil
- 06 - Write Single Register
- 15 - Write Multiple Coils
- 16 - Write Multiple Registers

Note: each of this command can read/write up to 10000 addresses.

Modbus TCP/IP slave unit

Modbus TCP slave has 10000 addresses in each memory section:

Coils:	00000 to 09999
Discrete inputs:	10000 to 19999
Input register:	30000 to 39999
Holding registers:	40000 to 49999

Supports up to 5 connections to the slave units (defined with MaxRemoteTCPClient parameter). Highest scan rate is 100 ms.

Modbus RTU master unit

When configured for Modbus RTU Master mode, the LPC-3.GOT.111 functions as a master device, controlling the communications with other slave devices such as sensors, inverters, other PLCs, etc. LPC-3.GOT.111 sends Modbus RTU commands to and receives Modbus RTU responses from the slave devices.

Following commands are supported:

- 01 - Read Coil Status
- 02 - Read Input Status



- 03 - Read Holding Registers
- 04 - Read Input Registers
- 05 - Write Single Coil
- 06 - Write Single Register
- 15 - Write Multiple Coils
- 16 - Write Multiple Registers

Note: each of this commands can read/write up to 246 bytes of data. For analog (Input and Holding registers) this means 123 values, while for digital (Statuses and Coils) this means 1968 values. When higher quantity of data is required, LPC-3.GOT.111 can execute up to 32 same or different supported commands simultaneous.

Physical layer: RS-485

Supported baud rates: 9600, 19200, 38400, 57600 and 115200bps

Parity: None, Odd, Even.

Stop bit: 1

Modbus RTU slave unit

Modbus TCP slave has 1024 addresses in each memory section:

Coils:	00000 to 01023
Discrete inputs:	10000 to 11023
Input register:	30000 to 31023
Holding registers:	40000 to 41023

Highest scan rate is 100 ms.

BACnet IP unit

When configured for BACnet IP (B-ACS), following commands are supported:

Data Sharing

- ReadProperty-B (DS-RP-B)
- WriteProperty-B (DS-WP-B)

Device and Network Management

- Dynamic Device Binding-B (DM-DDB-B)
- Dynamic Object Binding-B (DM-DOB-B)
- Device Communication Control-B (DM-DCC-B)
- Time Synchronization-B (DM-TS-B)
- UTCTimeSynchronization-B (DM-UTC-B)

For more information, please contact producer.

CANopen unit

CANopen unit consists of Master and Slave communication ports. They are independent, thus can be connected to two different CAN network at the same time.

The ports can operate at baud rates 50 kbps, 125 kbps or 250 kbps.

It follows the internationally standardized (EN 50325-4) CAN-based higher-layer protocol for embedded control systems. Advised rules and concepts by this standard must be followed to fulfill the conditions and so achieving normal operation and results.

The structure of the network as cable type and lengths, baud rates, number of the nodes and termination must be taken into account within the recommendations and requirements, when



designing the network.

The bus network can consist of at least one Master and at list one Slave node by the standard, but it is advised that with increased number of nodes, the Master node fastest interval is extended. Below are two examples:

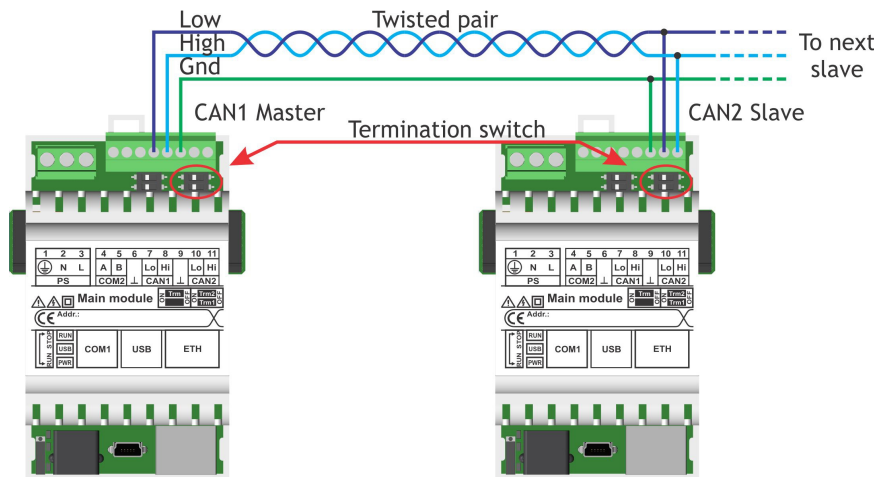
Example 1: network with 1 master and 9 slaves, every slave have defined 32 (4x8) byte of data and baud rate 125 Kbps. Fastest Cycle time for this configuration is 50 ms.

Example 2: network with 1 master and 4 slaves, every slave have defined 4 byte of data and baud rate 250 Kbps. Fastest Cycle time for this configuration is 5 ms.

5 ms is the fastest recommended cycle time.

It is recommended to power-up all the nodes on the same network at the same time, if some or all nodes had been reprogrammed (to reinitialize the communication properly).

Figure 8: CAN Master and Slave wiring diagram example



RUN/STOP Switch

Run: Status RUN status LED “on” indicate that the user graphical application is up and user program is running.

Stop: When the switch is turn to STOP state, the RUN status LED is “off” and user application is stopped.

PLC task cycle time

Main PLC task interval (under Project tab -> Resource → Tasks → Interval) time is not recommended to be set lower than 50 ms.



8.2 GUI design and programming

Figure 9: LPC Manager interface example⁸

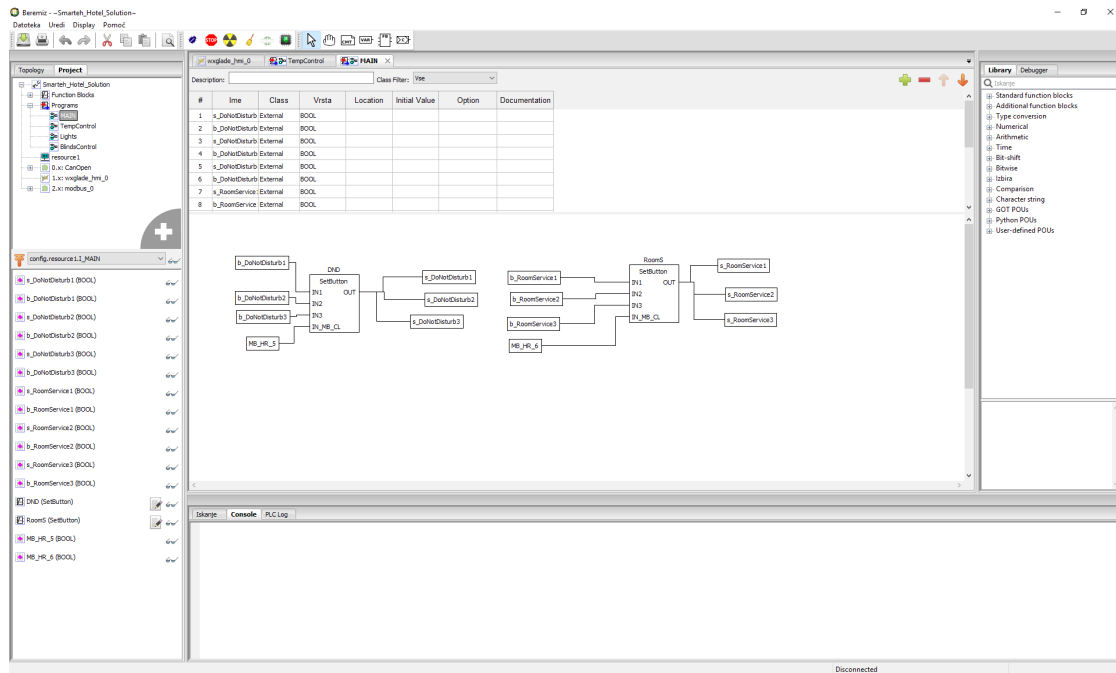
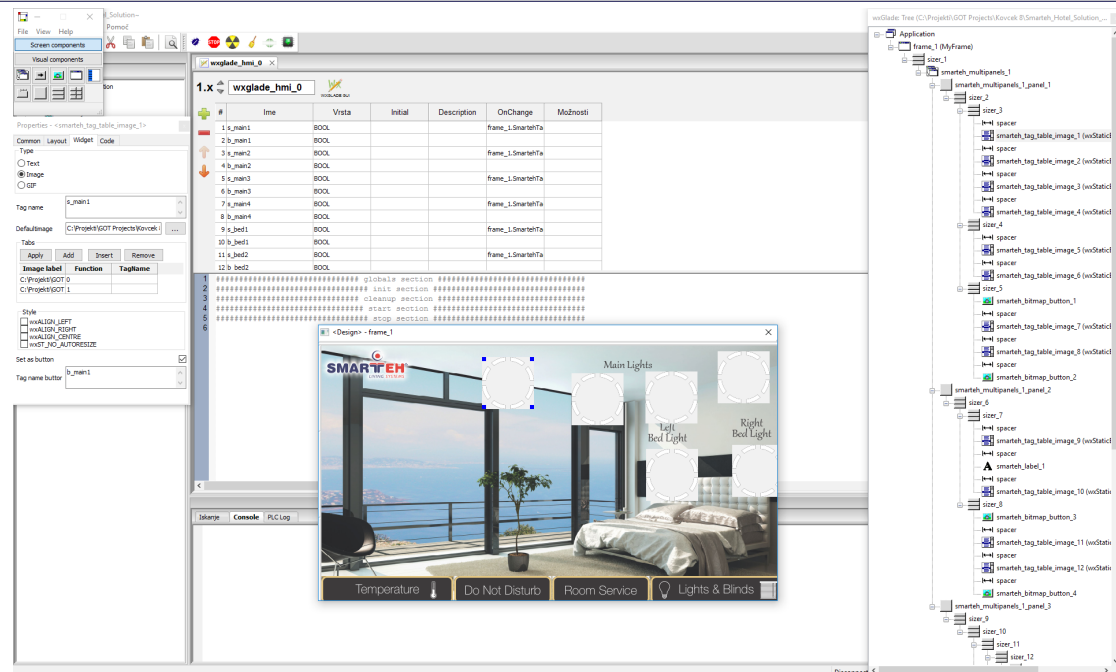


Figure 10: LPC GUI Manager interface example⁹



NOTE: Recommended minimum size of the touch object is 10 x 10 mm.

- 8 Configuration of the PLC is done using Smarteh IDE software tool. Please refer to LPC Manager user manual for details.
- 9 Configuration of the PLC is done using Smarteh IDE software tool. Please refer to LPC GUI Manager user manual for details.



9 MODULE LABELING

Figure 11: Labels

Label 1 (sample):

LPC-3.GOT.111
P/N:226GOT21111W04
D/C: 01/18

Label 2 (sample):

S/N: GOT-S9-1800001190

Label 3 (sample):

MAC: 20-41-5A-1A-00-00

Label 1 descriptions:

1. **LPC-3.GOT.111** is the full product name.
2. **P/N: 226GOT21111W04** is the part number.
 - **226** - general code for product family,
 - **GOT** - short product name,
 - **21111** - sequence code,
 - 21 - year of code opening,
 - 111 - derivation code,
 - **W04** - version code (reserved for future HW and/or SW firmware upgrades).
3. **D/C: 01/18** is the date code.
 - **01** - week and
 - **18** - year of production.

Label 2 descriptions:

1. **S/N:GOT-S9-1700001190** is the serial number.
 - **GOT** - short product name,
 - **S9** - user code (test procedure, e.g. Smarteh person xxx),
 - **1800001190** - year and current stack code,
 - 18 - year (last two cyphers),
 - 00000190 - current stack number; previous module would have the stack number 00000189 and the next one 00000191.

Label 3 description:

MAC: 20-41-5A-1A-00-00 is the MAC address.



10 SPARE PARTS

For ordering spare parts following Part Numbers should be used:

LPC-3.GOT.111 Graphical operation terminal	
LPC-3.GOT.111 - white	P/N: 226GOT21111W04
LPC-3.GOT.111 - black	P/N: 226GOT21111B04

Interconnection cable STK4-020	
STK4-020	P/N: 203STK17001001



11 CHANGES

The following table describes all the changes to the document.

Date	V.	Description
25.11.21	9	Figures update.
27.05.20	8	Figure 6 update.
16.04.20	7	Black version added.
27.03.20	6	Mounting instructions update.
09.03.20	5	Modbus chapter update.
24.10.19	4	BACnet description added.
01.03.18	3	Added chapter 5.4.
15.01.18	2	Technical data update.
30.09.17	1	The initial version, issued as <i>LPC-3.GOT.111 User Manual</i> .





12 NOTES

