



SMARTEH[®]
LIVING SYSTEMS

USER MANUAL

— Longo programmable controller
LPC-2.SM6
Multisensor

Version 4

Written by SMARTEH d.o.o.
Copyright © 2017, SMARTEH d.o.o.

User Manual

Document Version: 4
January, 2017



STANDARDS AND PROVISIONS: Standards, recommendations, regulations and provisions of the country in which the devices will operate, must be considered while planning and setting up electrical devices. Work on 100 .. 240 V AC network is allowed for authorized personnel only.

DANGER WARNINGS: Devices or modules must be protected from moisture, dirt and damage during transport, storing and operation.

WARRANTY CONDITIONS: For all modules LONGO LPC-2 - if no modifications are performed upon and are correctly connected by authorized personnel - in consideration of maximum allowed connecting power, warranty of 24 months is valid from the date of sale to the end buyer, but not more than 36 months after delivery from Smarteh. In case of claims within warranty time, which are based on material malfunctions the producer offers free replacement. The method of return of malfunctioned module, together with description, can be arranged with our authorized representative. Warranty does not include damage due to transport or because of unconsidered corresponding regulations of the country, where the module is installed.

This device must be connected properly by the provided connection scheme in this manual. Misconnections may result in device damage, fire or personal injury.

Hazardous voltage in the device can cause electric shock and may result in personal injury or death.

NEVER SERVICE THIS PRODUCT YOURSELF!

This device must not be installed in the systems critical for life (e.g. medical devices, aircrafts, etc.).

If the device is used in a manner not specified by the manufacturer, the degree of protection provided by the equipment may be impaired.

Waste electrical and electronic equipment (WEEE) must be collected separately!

LONGO LPC-2 complies to the following standards:

- EMC: EN 61000-6-3:2007 + A1:2011, EN 61000-6-1:2007, EN 61000-3-2:2006 + A1:2009 + A2: 2009, EN 61000-3-3:2013
- LVD: IEC 61010-1:2010 (3rd Ed.), IEC 61010-2-201:2013 (1st Ed.)

Smarteh d.o.o. operates a policy of continuous development. Therefore we reserve the right to make changes and improvements to any of the products described in this manual without any prior notice.

MANUFACTURER:

SMARTTEH d.o.o.
Poljubinj 114
5220 Tolmin
Slovenia



Index

Longo programmable controller LPC-2.SM6

- 1 ABBREVIATIONS.....1
- 2 DESCRIPTION.....2
- 3 FEATURES.....3
- 4 OPERATION.....4
 - 4.1 Operational modes.....4
 - 4.2 Parameters.....4
 - 4.3 IR learn, receive and transmit.....6
- 5 INSTALLATION.....7
 - 5.1 Connection scheme.....7
 - 5.2 Mounting instructions.....9
 - 5.3 Module labeling.....11
- 6 TECHNICAL SPECIFICATIONS.....12
- 7 SPARE PARTS.....13
- 8 CHANGES.....14
- 9 NOTES.....15



1 ABBREVIATIONS

Sorted by order of appearance in document:

LED	Light emitting diode
SEL	Selector
VOC	Volatile organic compound
PIR	Passive infrared sensor
IR	Infrared



2 DESCRIPTION

The LPC-2.SM6 is a multi sensor which consists of the following sensors: VOC sensor for VOC level measurements, lux sensor for light intensity measurements, PIR sensor for occupancy sensing and IR receive/transmit for IR communication.

Measuring VOC level and light intensity provides the information needed for achieving good work conditions. Information about occupancy of the room can be used for energy saving algorithms. IR transmit feature can be used for remote controller substitution, for example air conditioning can be controlled from Smarteh main module via LPC-2.SM6 in parallel with remote controller. On the other hand, IR receive feature can be used for receiving commands to the main module from Smarteh remote controller, smartphone or other remote controller. LPC-2.SM6 can recognize RC-5 IR protocol which is used in Smarteh remote controller or 15 different learned IR commands which can be learned in IR learning mode. Only learned commands can be transmitted.

LPC-2.SM6 is controlled and powered from the main module (e.g., LPC-2.MC8, LPC-2.MC9) via Smarteh bus.



3 FEATURES



Figure 1: LPC-2.SM6 multisensor

Table 1: Features
VOC sensor for VOC measurement
PIR sensor for occupancy detection
Lux sensor for light intensity measurement
IR receive/transmit
Mounting with integrated magnets or screws ¹
2 diagnose LED

¹ Screws are not supplied with sensor.



4 OPERATION

LPC-2.SM6 can be in one of two operational modes - normal or error. When LPC-2.SM6 is in normal mode, module parameters can be read or written via Smarteh IDE software.

4.1 Operational modes

Normal

Communication with the main module is working. Only green “PWR” LED2 is turned on.

Error

In case of communication fault, red “ERR” LED1 will turn on.

4.2 Parameters

If parameter is set to logical “1”, is considered to be active, enabled or set. If parameter has logical value “0” is considered to be inactive, disabled or cleared.

Parameter can be a command or feedback. When parameter is marked as feedback it means that LPC-2.SM6 is sending information to the main module. On the other hand, command represents request from the main module to the LPC-2.SM6.

Command:

IR command number selection for transmit [*olrCmdSendNum*]: This parameter is used to select the IR learned command which will be used for transmit.

Type: WORD

Raw to engineering data: 1 .. 15 → IR transmit command 1 .. IR transmit command 15

IR command transmit control bit [*olrCmdSend*]: When this bit goes to “1”, selected IR command in *olrCmdSendNum* is transmitted.

Type: BOOL

Raw to engineering data: “0” → No transmit

“1” → Transmit selected IR command

IR protocol selector [*olrProtocolSel*]: Selector for IR receive protocol.

Type: WORD

Raw to engineering data: 0 → Learned IR commands

1 → RC-5 IR protocol

Feedback:

Actual VOC value [*iVoc*]: Actual measured VOC value.

Type: WORD

Raw to engineering data: 450 .. 2000 → 450 .. 2000 ppm

VOC sensor run status [*iVocStatus*]: This bit is “1” whenever VOC sensor reports fault, busy or warming up state. After power-on the *iVocStatus* will be “1” because of warming up state which can take up to 10 minutes. In case VOC sensor is busy during reading, the *iVocStatus* will be “1” until VOC sensor is not busy anymore. If *iVocStatus* remains “1” for longer periods, it means that the sensor may be faulty.

Type: BOOL

Raw to engineering data: “0” → *iVoc* data valid

“1” → Fault/busy/warming up



Actual light intensity value [*iLight*]: Actual measured light intensity value.

Type: WORD

Raw to engineering data: 0 .. 1490 → 0 .. 1490 lux

PIR sensor detection status [*iPirDetect*]: Moving person or object presence indication.

Type: BOOL

Raw to engineering data: “0” → No moving person or object presence indication
 “1” → Moving person or object presence indication

Toggle communication bit [*iComm*]: At each valid Rx packet from main module, this bit is toggled.

Type: BOOL

IR command number received value [*ilrCmdRecNum*]: This parameter depends on the *olrProtocolSel* parameter. Latency between touched button on the remote controller and reception on the main module is max. 1 s.

Type: WORD

If *olrProtocolSel* is "0":

When LPC-2.SM6 receives an IR command, value of *ilrCmdRecNum* corresponds to the number of the IR learned command. Value is set back to 0 after next communication cycle with main module or after approximately two seconds regardless communication.

Raw to engineering data: 1 .. 15 → IR receive learned command 1 .. IR receive learned command 15

is "1":

When LPC-2.SM6 receives an IR command, value of *ilrCmdRecNum* corresponds to the number described below in binary code which includes toggle bit, address code and data code of the RC-5 protocol. When button is released, value gets to 0 after next communication cycle with main module or after approximately two seconds regardless communication.

Raw to engineering data:

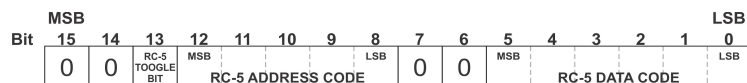

4.3 IR learn, receive and transmit

LPC-2.SM6 module can be learned to recognize 15 different IR commands. Module enters IR learning mode as soon as the left pair of DIP switches (S1) are not in position for "No learning - receive only" - see table 4.

IR learn is demonstrated on the example on how to learn LPC-2.SM6 the IR command "power ON" from third-party IR remote controller for air conditioning and store it under command 15 in the LPC-2.SM6 internal memory. IR receive and transmit is demonstrated on the example how to verify stored IR commands.

IR learn

Set the S1 DIP switches to the setting than corresponds to the number under which IR command will be stored. In this example, switches must be set to setting "learning mode for command 15". Once this is done, LPC-2.SM6 is ready to receive the IR command from the remote controller and store it to internal memory under command 15.

Press the button on the IR remote controller which you want it to be stored under command that is set with DIP switches on LPC-2.SM6. In this example, press "power ON" button on the IR remote controller. Once the button has been pressed, the LPC-2.SM6 stores the IR command to internal memory, in this example under command 15. LPC-2.SM6 will not store any other command under command 15, unless S1 DIP switches has been changed to other setting and back to the setting "learning mode for command 15".

IR receive

Which protocol should be used for IR receive, user can select with *IrProtocolSel* parameter. To check if the IR command has been learned and stored correctly *IrProtocolSel* parameter must be "0".

Set the DIP switches to the setting "No learning - receive only" and than press button "power ON" on the IR remote controller. If the received IR command corresponds to any of the IR commands stored in the LPC-2.SM6 internal memory, the command number under which the received IR command has been stored will be shown in the feedback parameter *ilrCmdRecNum*. In this example, number 15 should be shown.

If *IrProtocolSel* is set to "0" and DIP switches to the setting "No learning - receive only" than LPC-2.SM6 will receive learned IR commands only.

If *IrProtocolSel* is set to "1" and DIP switches to the setting "No learning - receive only" than LPC-2.SM6 will receive RC-5 IR protocol only.

Be advised that during IR transmit, IR receive is blocked.

IR transmit

In order to check if the IR command that was stored can also be transmitted correctly, the LPC-2.SM6 should be used as a substitution of the IR remote controller. On the main module, number 15 should be written to the LPC-2.SM6 command *olrCmdSendNum*. This command selects IR command which is stored under number 15 for transmit. IR transmit is executed once *olrCmdSend* is set to logical "1". In this example, air conditioning should be turned ON.

Procedure for IR learn can be repeated for 15 different IR commands. DIP switch setting corresponds to learning mode for one of 15 commands and IR receive only mode - see table 4.

The IR commands may also be learned during manufacturing process - consult with Smarteh.



5 INSTALLATION

5.1 Connection scheme

Figure 2: Connection scheme

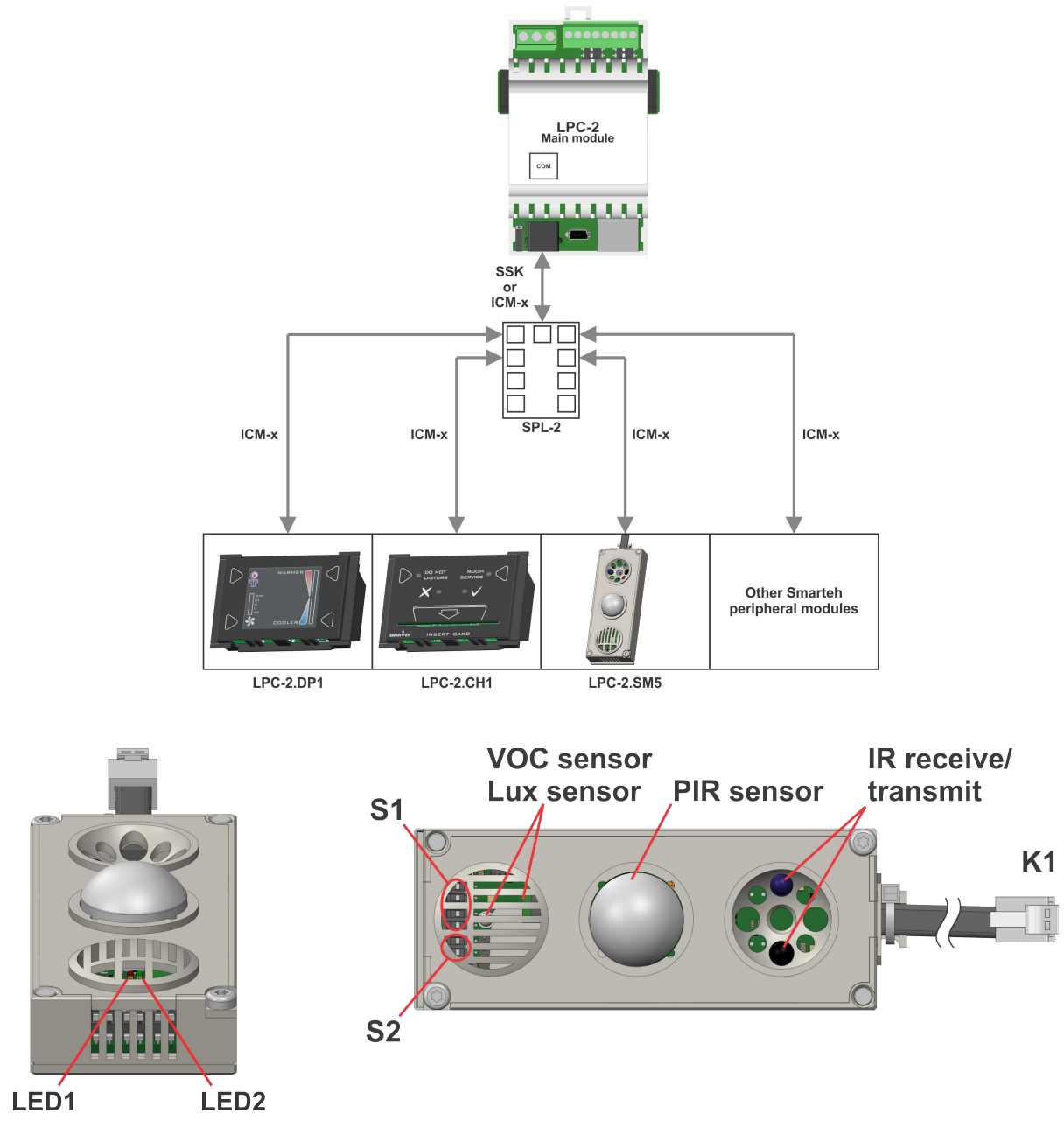

Table 2: K1

K1.1	GND	Ground
K1.2	7 .. 30 V DC	Power supply input
K1.3	Standard RS-485 A	Data receive/send line A
K1.4	Standard RS-485 B	Data receive/send line B

Table 3: LEDs

LED1: red	Communication	ON: RS-485 communication fault OFF: RS-485 communication OK
LED2: green	Power supply	ON: power supply OK OFF: power supply missing or power off

Table 4: S1

SEL for IR	Switch 1	Switch 2	Switch 3	Switch 4
No learning - IR receive only	OFF	OFF	OFF	OFF
Learning mode for command 1	OFF	OFF	OFF	ON
..
..
Learning mode for command 14	ON	ON	ON	OFF
Learning mode for command 15	ON	ON	ON	ON

Table 5: S2

RS-485 ADDRESS	Switch 1	Switch 2
0	OFF	OFF
1	OFF	ON
2	ON	OFF
3	ON	ON



5.2 Mounting instructions

Figure 3: Housing dimensions

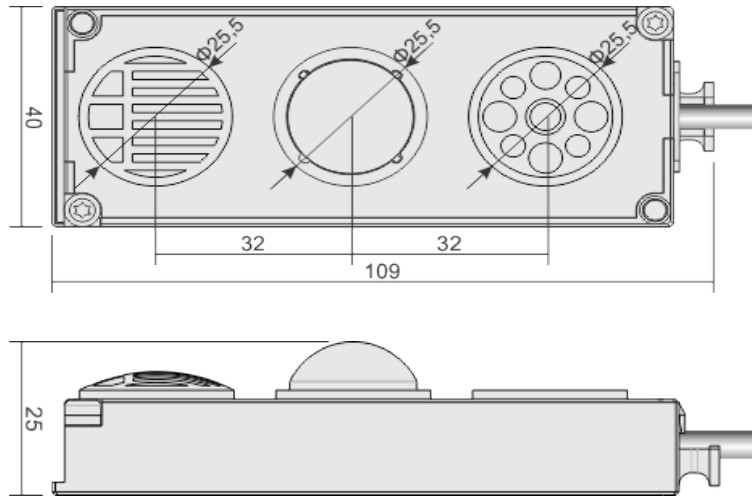

Dimensions in millimeters.



All connections, module attachments and assembling must be done while module is not connected to the main power supply.

Mounting instructions:

1. Set the correct RS-485 address for LPC-2.SM6 (refer to the table 5).
2. Install the LPC-2.SM6 module on the position which provides maximum effect for its features with the magnets or screws². Magnets can be pushed to the other side of abutment surface if needed.
3. Connect interconnection cable to the main module.

LPC-2.SM6 module must be installed properly, isolating any potential connection with electrical sources other than power supply from main module. Improperly installed module may cause failure of the module itself, other devices on the same wiring, main module or may lead to fire or personal injury.

LPC-2.SM6 is connected to the main module with interconnection cable (e.g. SSK, ICM-7). When more modules are connected to the main module, splitter (e.g. SPL-2) is also required (figure 2).

NOTE: Signal wires must be installed separately from power and high voltage wires in accordance with general industry electrical installation standard.

² Screws are not supplied with sensor.



Figure 4: LPC-2.SM6 orientation

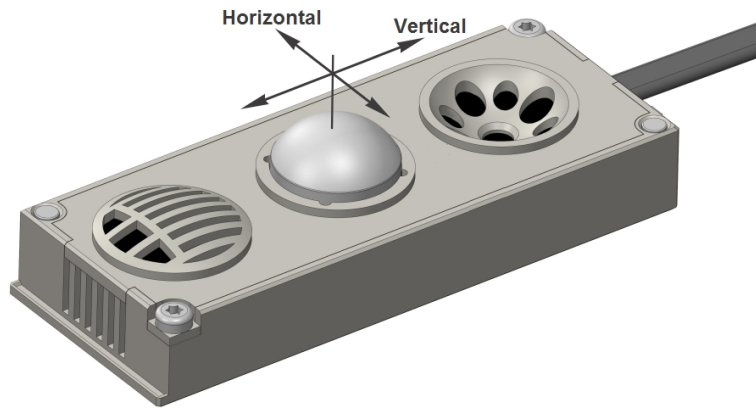
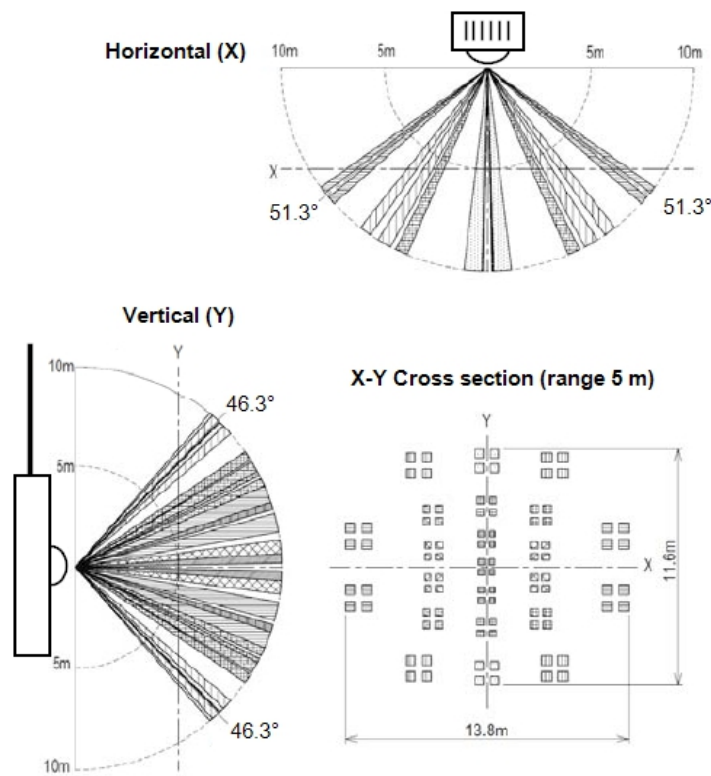

Figure 5: PIR sensor detection area



5.3 Module labeling

Figure 6: Labels

Label 1 (sample):

LPC-2.SM6
 P/N:225SM616001001
 D/C: 01/16

Label 2 (sample):

S/N: SM6-S9-1600000003

Label 1 descriptions:

1. **LPC-2.SM6** is the full product name.
2. **P/N: 225SM616001001** is the part number.
 - **225** - general code for product family,
 - **SM6** - short product name,
 - **16001** - sequence code,
 - **16** - year of code opening,
 - **001** - derivation code,
 - **001** - version code (reserved for future HW and/or SW firmware upgrades).
3. **D/C: 01/16** is the date code.
 - **01** - week and
 - **16** - year of production.

Label 2 descriptions:

1. **S/N: SM6-S9-1600000003** is the serial number.
 - **SM6** - short product name,
 - **S9** - user code (test procedure, e.g. Smarteh person xxx),
 - **1600000003** - year and current stack code,
 - **16** - year,
 - **00000003** - current stack number; previous module would have the stack number 00000002 and the next one 00000004.



6 TECHNICAL SPECIFICATIONS

Table 6: Technical specifications

Power supply	from main module
Interconnection connector type	RJ-12 6/6
Power consumption	0.5 W
VOC measurement range	450 .. 2000 ppm
Light intensity measurement range	0 .. 1490 lux ³
PIR sensor detection range	max. 12 m
PIR sensor detection area	vertical: 92° (± 46°) horizontal: 102° (± 51°) detection zones: 92
PIR sensor conditions concerning detection	the temperature difference between the moving person or object and the surroundings should be superior to 4 °C (7.2 °F). movement speed: 1.0 m/s target concept is human body (size: 700 x 250 mm)
IR frequency carrier	38 kHz
IR max. pulse length in protocol used for learning	16 ms
IR min. pulse length in protocol used for learning	250 us
IR max. number of pulses for learning single IR command	540
Dimensions (W x H x D)	109 x 40 x 20 mm
Weight	65 g
Maximum altitude	2000 m
Mounting position	any
Ambient temperature	0 to 50 °C
Ambient humidity	max. 95 %, no condensation
Transport and storage temperature	-20 to 60 °C
Protection class	IP 20

³ Due to various spectral sensitivity of the various lux sensors on the market, the actual light intensity may vary.



7 SPARE PARTS

For ordering spare parts following Part Numbers should be used:

LPC-2.SM6 Multisensor	
LPC-2.SM6	P/N: 225SM616001001

Interconnection cable	
ICM-x	P/N: 203ICMxxxxxxxx

Splitter	
SPL-2 (1/8)	P/N: 206SPL04002001



8 CHANGES

The following table describes all the changes to the document.

Date	V.	Description
15.01.17	4	Technical update.
16.11.16	3	Added IR data.
28.10.16	2	Parameter added in section 4.2.
30.09.16	1	The initial version, issued as <i>LPC-2.SM6 User Manual</i> .





9 NOTES

