



SMARTEH[®]
LIVING SYSTEMS

USER MANUAL

- ▶ Longo programmable controller
LPC-2.P02V
Temperature Control panel

Version 2

Written by SMARTEH d.o.o.
Copyright © 2017, SMARTEH d.o.o.

User Manual

Document Version: 2
March, 2017

STANDARDS AND PROVISIONS: Standards, recommendations, regulations and provisions of the country in which the devices will operate, must be considered while planning and setting up electrical devices. Work on 100 .. 240 V AC network is allowed for authorized personnel only.

DANGER WARNINGS: Devices or modules must be protected from moisture, dirt and damage during transport, storing and operation.

WARRANTY CONDITIONS: For all modules LONGO LPC-2 - if no modifications are performed upon and are correctly connected by authorized personnel - in consideration of maximum allowed connecting power, warranty of 24 months is valid from the date of sale to the end buyer, but not more than 36 months after delivery from Smarteh. In case of claims within warranty time, which are based on material malfunctions the producer offers free replacement. The method of return of malfunctioned module, together with description, can be arranged with our authorized representative. Warranty does not include damage due to transport or because of unconsidered corresponding regulations of the country, where the module is installed.

This device must be connected properly by the provided connection scheme in this manual. Misconnections may result in device damage, fire or personal injury.

Hazardous voltage in the device can cause electric shock and may result in personal injury or death.

NEVER SERVICE THIS PRODUCT YOURSELF!

This device must not be installed in the systems critical for life (e.g. medical devices, aircrafts, etc.).

If the device is used in a manner not specified by the manufacturer, the degree of protection provided by the equipment may be impaired.

Waste electrical and electronic equipment (WEEE) must be collected separately!

LONGO LPC-2 complies to the following standards:

- EMC: EN 61000-6-3:2007 + A1:2011, EN 61000-6-1:2007, EN 61000-3-2:2006 + A1:2009 + A2: 2009, EN 61000-3-3:2013
- LVD: IEC 61010-1:2010 (3rd Ed.), IEC 61010-2-201:2013 (1st Ed.)

Smarteh d.o.o. operates a policy of continuous development. Therefore we reserve the right to make changes and improvements to any of the products described in this manual without any prior notice.

MANUFACTURER:

SMARTEH d.o.o.
 Poljubinj 114
 5220 Tolmin
 Slovenia



Index

Longo programmable controller LPC-2.P02V

1 ABBREVIATIONS.....1

2 DESCRIPTION.....1

3 FEATURES.....2

4 OPERATION.....3

 4.1 Operational modes.....3

 4.2 Functions3

 4.3 Parameters.....4

5 INSTALLATION.....6

 5.1 Connection scheme.....6

 5.2 Mounting frame selection.....8

 5.3 Mounting instructions.....9

 5.4 Module labeling.....10

6 REGULATION DIAGRAM.....11

7 TECHNICAL SPECIFICATIONS.....12

8 SPARE PARTS.....13

9 CHANGES14

10 NOTES.....15

1 ABBREVIATIONS

SP	Set-point
CP	Control panel
PB	Push button
LED	Light emitting diode

2 DESCRIPTION

LPC-2.P02V control panel (CP) is used for room temperature regulation.

Panel is equipped with temperature and light intensity sensor and two push buttons (PB). To increase, decrease temperature set point *warmer*, *cooler* PB should be pressed respectively. Temperature SP and panel switched off mode are represented with LED bar-graph. Light intensity sensor controls LED bar-graph intensity.

All parameters are accessible on panel's communication port. When panel is connected to the LPC-2 main module parameters can be viewed and modified with Smarteh IDE application.

LPC-2.P02V parameters and functions allows adaptation to desired system and regulation diagram.

Panel is able to regulate 2-pipe or 4-pipe systems, depending on *4/2 pipe* parameter.

LPC-2.P02V is controlled and powered from the main module (e.g., LPC-2.MC9) via Smarteh bus.

3 FEATURES



Figure 1: LPC-2.P02V module

Table 1: Features

Room temperature measurement
2 push buttons for temperature set point
10 LED bar-graph for temperature set point
Light intensity measurement
LED intensity control
Economic function
2/4 pipe heating cooling system supported
Balcony door and window function
Frost protection function
Power LED
Internal fault LED

4 OPERATION

Basic setting can be entered with panel Push Buttons (PB).

Modes of operation and parameters can be set via Smarteh IDE software, some of them can be also activated through special sequence PB pressing.

4.1 Operational modes

Changing operation modes

Switching between modes is done with PB1 (SP Up):

pressed 5 s - switch to *economic* mode

pressed 10s - switch to *Off* mode

Exit to normal mode is executed with a short press on a PB1 (SP Up).

Normal

This is default mode of operation of P01V module.

Economic

If set, controller will start cooling when room temperature will raise above max. temp. setpoint (SP) and stop when temperature will drop 1 °C below max. temp. SP. On the other hand, when room temperature fall's below min. temp. SP controller will start heating and stop when temperature will raise 1 °C above min. temp. SP.

In economic mode setpoint LED in barLED1 is blinking.

Off

In this mode panel sends command to switch off all devices: hot valve, cold valve, LED's. CP can be turned off using *Fan* PB or *System On/Off* command. In this case cool, heat and fan commands are switched off. Cool and heat commands are also switched off when temperature measured by the panel is inside temperature deadband values (default = 0.5 °C).

4.2 Functions

PI controller

Output variable range is 0 to 10000. Values from 0 to 4999 represents cooling and values from 5000 up to 10000 represents heating.

Example: If proportional - P parameter (default = 25) is set to 1 and difference between measured temperature and temperature set point is +1 °C, the PI output value will be 5100. On the other hand if the difference is -1 °C, the control panel regulator output value will be 4900.

If integral - I parameter (default = 5) is set to 1 and difference between measured temperature and temperature set point is +1 °C, the control panel regulator output will increase every second by 100. On the other hand if the difference is -1 °C, the control panel regulator output will decrease every second by 100.

2/4 pipe system selection

While 4-pipe (factory default) system active, controller will activate hot water actuator when heating is required and cool water actuator when cooling is required.

In case 2-pipe system is active, hot water actuator will be operated regardless whether heating or cooling is needed. Mode of operation (closing, opening) is dependent on *Winter/Summer* parameter.

Example:

System selected is 2-pipe , summer mode active and SP is lower than room temperature. CP will start cooling with activating heat valve. In 2-pipe system cool valve is always inactive.

Frost protection

Function activates heat command when room temperature measured by the panel drops below 5 °C. This function has priority over all control panel integrated functions.

Open window

Panel will operate in special mode if open window and opened balcony door are detected. This function is enabled by enabling parameters *Balcony door En.* or *Window En.* When this function is active and one of parameters *Window* or *Balcony Door* commands is active, fan will go to the first (I.) speed and valves for heating and cooling will be closed.

4.3 Parameters

If parameter is set to logical “1”, is considered to be active, enabled or set. If parameter has logical value “0” is considered to be inactive, disabled, or cleared.

Parameter can be status or command or both. When parameter is marked as status this means that module is sending information to controller. On the other hand command represents request from module to main module.

Communication: Normal state is “1”. If cleared, there is communication error or no communication established.

Normal/Economic: When set Economic mode is enabled. Default value is “0”, therefore normal mode is selected.

Local/Remote: When “0”, Local mode is selected. In this mode CP uses setpoint set by PB. In remote mode, “1”, CP uses setpoint received from other devices (HMI, Touch Panel, OT1, ..) through communication channel.

Heat valve: When valve is opened “1” is reported, while “0” stands for closed valve

Cool valve: When valve is opened “1” is reported, while “0” stands for closed valve

System On/Off: If parameter is set to “1” CP functions are executing in normal mode. If set to “0” Fan speed and all valves are OFF (closed).

Winter/Summer: Used only for *two-pipe system* to change calculation for Hot valve and Fan speed; Winter - heating (“0”) to Summer - cooling (“1”)

4/2 pipe: Four-pipe system manages hot and cold water pipes simultaneously. Two-pipe system manages only one pair of pipes (one valve, pump). Operation in two-pipe system is therefore dependent on *Change-over* parameter.

“0” = Four pipe system

“1” = Two pipe system

Balcony door En.: When switch for detecting opened balcony door is connected to the system, this function should be enabled (“1”).

Balcony door switch: Parameter reports whether door are closed or opened

“0”: closed

“1”: opened

Window En.: When switch for detecting opened window is connected to the system, this function should be enabled (“1”).

Window: Parameter reports whether window is closed or opened

“0”: closed

“1”: opened

Max. temp.: denotes max. SP temp. which is scaled to top of barLED1

Min. temp.: denotes min. SP temp. which is scaled to bottom of barLED1

P regulation par.: Proportional parameter for PI calculation algorithm on CP

I regulation par.: Integral parameter for PI calculation algorithm on CP

PI Deadband: Value of change for PI loop output.

Temp. SP: This value is taken into PI calculation algorithm

Room temp.: Room temperature measured by CP panel

Absolute PI out: Result of PI calculation algorithm used for fan speed and valve opening

Light intensity: Actual light intensity measured by sensor on CP

Min. light intensity: When *Light intensity* is lower than this parameter, LED bargraph on CP turns off

Remote temp. SP: When *Local/Remote* parameter is active this parameter is taken into PI calculation algorithm as SP.

SP up: When *Local/Remote* parameter is active and this command changes to active, CP will increment SP for 1/10 of scale. It acts like one press on *Up* PB1 on CP.

SP down: When *Local/Remote* parameter is active and this command changes to active, CP will decrement SP for 1/10 of SP range. It acts like one press on *Down* PB2 on CP.

5 INSTALLATION

5.1 Connection scheme

Figure 2: Connection scheme

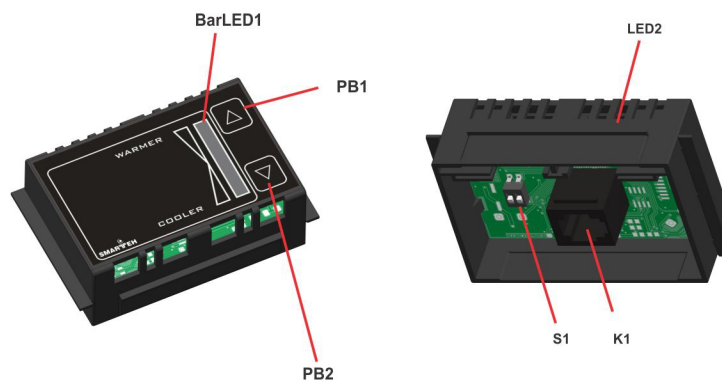
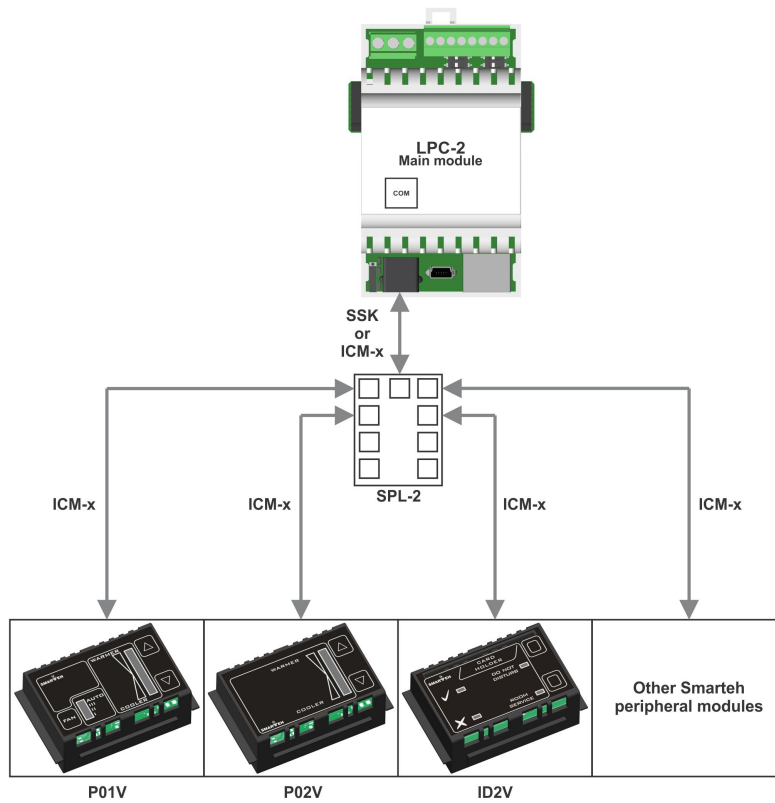

Table 2: K1

K1.1	GND	Ground
K1.2	7 .. 30 V DC	Power supply input
K1.3	Standard RS-485 A	Data receive/send line A
K1.4	Standard RS-485 B	Data receive/send line B

Table 3: LEDs & Buttons

LED2: red	Communication	ON: RS-485 communication fault OFF: RS-485 communication OK
BarLED1	Temp. SP	lit LED presents actual set point relative to range <i>Min. temp.</i> (bottom barLED) - <i>Max. temp.</i> (top barLED)
PB1	SP up	Increase by one step, step = $(Max. temp - Min. temp) * 1/10$
PB2	SP down	Decrease by one step, step = $(Max. temp - Min. temp) * 1/10$

Table 4: S1

RS-485 ADDRESS	Switch 1	Switch 2
0	OFF	OFF
1	OFF	ON
2	ON	OFF
3	ON	ON

5.2 Mounting frame selection

SmarteH has verified following lines to be compatible with LPC-2.P02V module:

- Bticino - Living, Light
- Gewiss - Playbus, System
- Vimar - Plana, Idea
- Tem
- Master

Frames of other vendors most probably suits as well, but they were not verified by SmarteH. Before installation verify compatibility of non listed frames.

Module housing has a fin on each side, which can be easily removed with knife cutter or pliers. This adaptation enables housing to be build in various frame formats. With regard to frame used you may remove fin for housing to fit in.

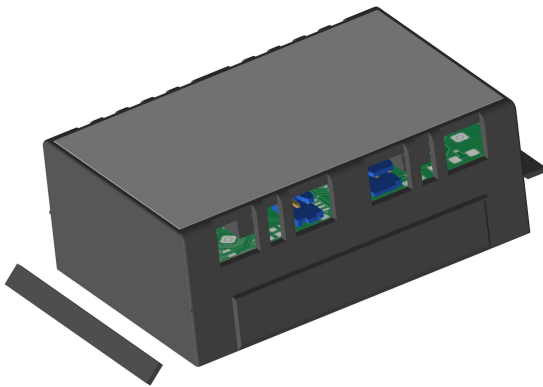
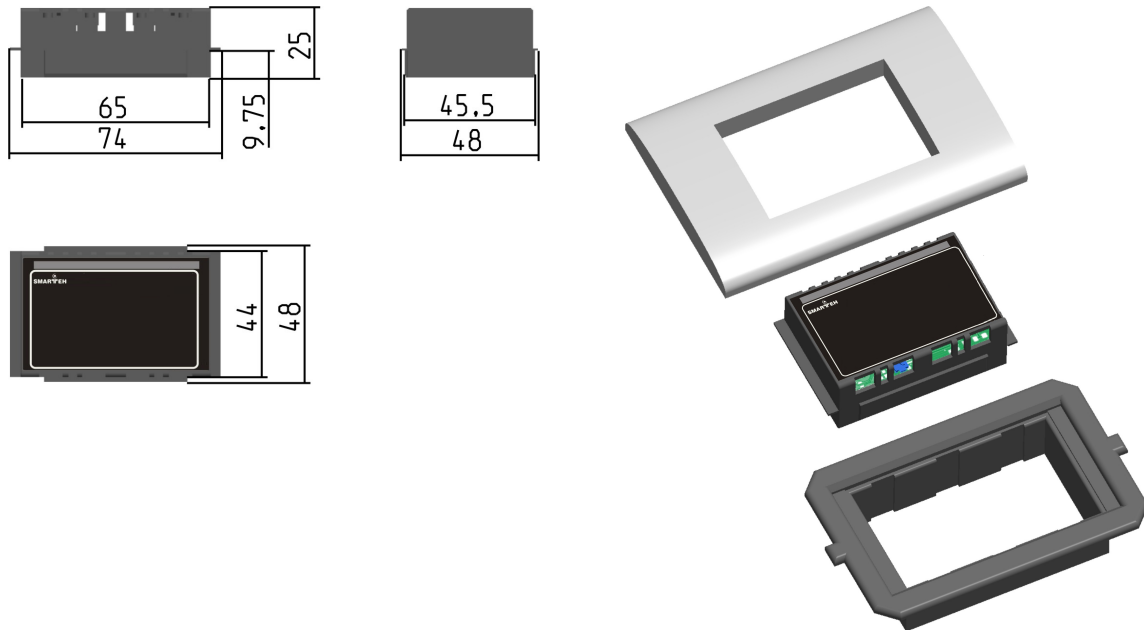

Figure 1: Module with removable fin

5.3 Mounting instructions

Figure 3: Housing dimensions



Dimensions in millimeters.



All connections, module attachments and assembling must be done while module is not connected to the main power supply.

Module should be positioned in the wall inside of the room. Avoid direct sunlight or positioning near heating/cooling source object.

Mounting instructions:

1. Set the correct RS-485 address (S1 switch) for LPC-2.P02V (refer to the Table 4).
2. Connect interconnection cable to the connector K1. Max. allowed tractive force is 30 N.
3. Put the LPC-2.P02V in mounting frames.
4. Cover LPC-2.P02V with cover plate.

LPC-2.P02V is connected to the main module with interconnection cable (e.g. SSK, ICM-7) which must be ordered together with LPC-2.P02V module. When more modules are connected to the main module, splitter (e.g. SPL-2) is also required (Figure 2). Signal wires must be installed separately from power and high voltage wires in accordance with general industry electrical installation standard.

NOTE: Signal wires must be installed separately from power and high voltage wires in accordance with general industry electrical installation standard.

5.4 Module labeling

Figure 5: Labels

Label 1 (sample):

LPC-2.P02V
P/N:225P0208V01001
D/C: 40/08

Label 2 (sample):

S/N: P02V-S9-0800000003

Label 1 description:

- **LPC-2.P02V** is the full product name.
- P/N: 225P0208V01001 is the part number.
 - 225 - general code for LPC-2 product family,
 - P02 - short product name,
 - 08 - year of code opening,
 - V - denotes flush frame mounting module,
 - 01 - derivation code,
 - 001 - version code (reserved for future HW and/or SW firmware upgrades).
- D/C: 40/08 is the date code.
 - 40 - week and
 - 08 - year of production.

Label 2 description:

- S/N: P02V-S9-0800000003 is the serial number.
 - P02V - short product name,
 - S9 - user code (test procedure, e.g. Smarteh person xxx),
 - 08 - year (last two cyphers),
 - 00000003 - current stack number; previous module would have the stack number 00000002 and the next one 00000004.

6 REGULATION DIAGRAM

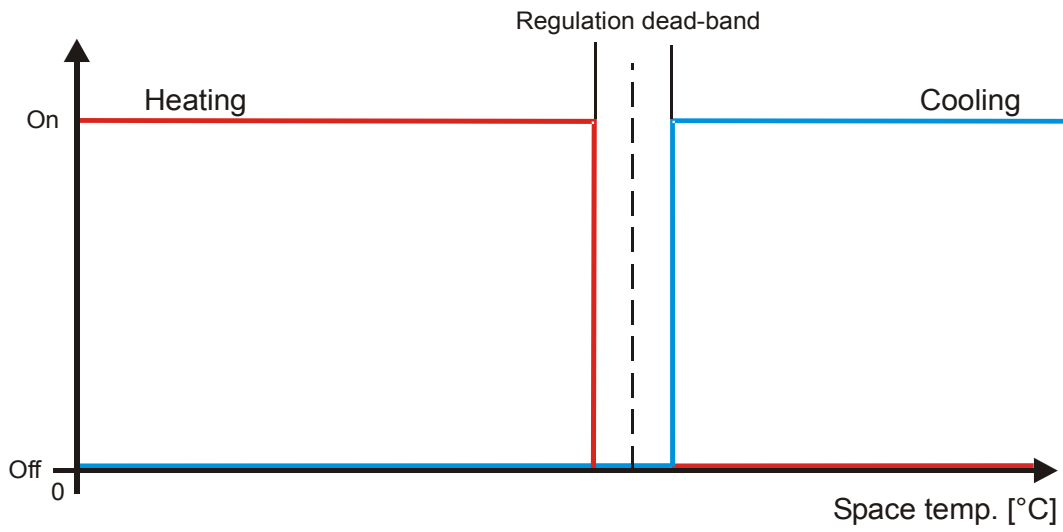

Fan reference output

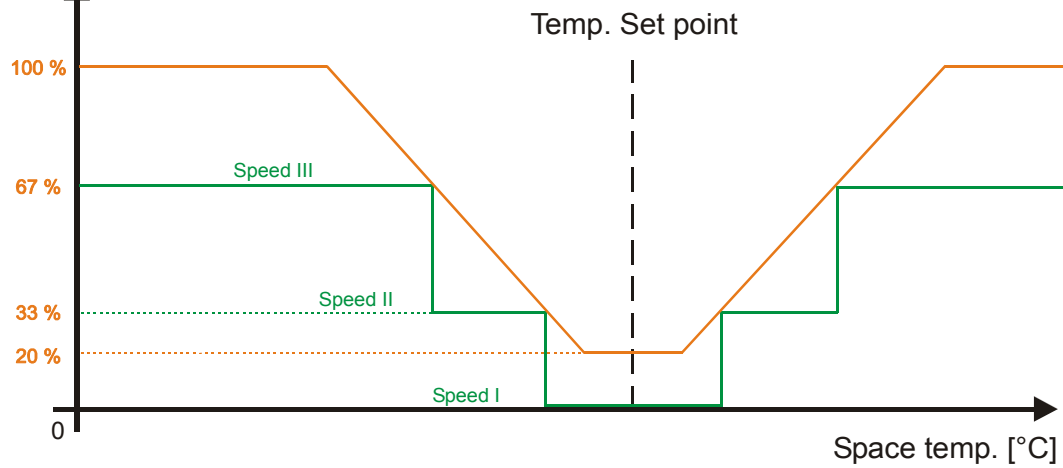

PI regulator output

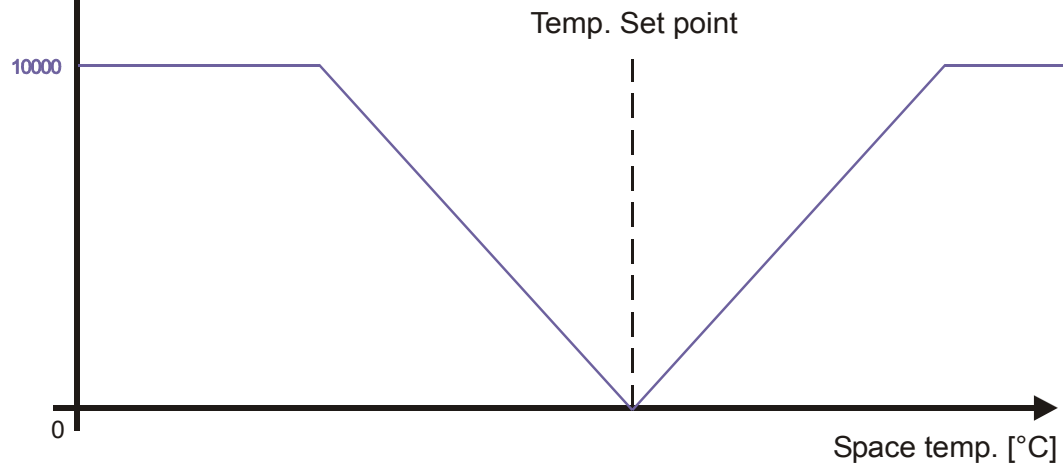

7 TECHNICAL SPECIFICATIONS

Table 5: Technical specifications

Power supply	from main module
Interconnection connector type	RJ-12 6/6
Power consumption	0.5 W
Dimensions (W x H x D)	65 x 47 x 25 mm
Weight	35 g
Maximum altitude	2000 m
Mounting position	all directions
Ambient temperature	0 to 50 °C
Ambient humidity	max. 95 %, no condensation
Transport and storage temperature	-20 to 60 °C
Protection class	IP 20

8 SPARE PARTS

For ordering spare parts following Part Numbers should be used:

LPC-2.P02V temperature control panel, black	
LPC-2.P02V	P/N: 225P0208V02002
LPC-2.P02V temperature control panel, white	
LPC-2.P02V	P/N: 225P0208V01002
Interconnection cable	
ICM-x	P/N: 203ICMxxxxxxxx
Interconnection cable	
SSK	P/N: 203SSK05001001
Splitter	
SPL-2 (1/8)	P/N: 206SPL04002001



9 CHANGES

The following table describes all the changes to the document.

Date	V.	Description
15.03.17	2	General update.
28.02.09	1	The initial version, issued as <i>LPC-2.P02V module UserManual</i> .

10 NOTES
