



**SMARTEH**<sup>®</sup>  
LIVING SYSTEMS

# USER MANUAL

— Longo programmable controller  
LPC-2.MM2  
Main module

Version 1

Written by SMARTEH d.o.o.  
Copyright © 2023, SMARTEH d.o.o.

User Manual

Document Version: 1  
December, 2023



**STANDARDS AND PROVISIONS:** Standards, recommendations, regulations and provisions of the country in which the devices will operate, must be considered while planning and setting up electrical devices. Work on 100 .. 240 V AC network is allowed for authorized personnel only.

**DANGER WARNINGS:** Devices or modules must be protected from moisture, dirt and damage during transport, storing and operation.

**WARRANTY CONDITIONS:** For all modules LONGO LPC-2 - if no modifications are performed upon and are correctly connected by authorized personnel - in consideration of maximum allowed connecting power, warranty of 24 months is valid from the date of sale to the end buyer, but not more than 36 months after delivery from Smarteh. In case of claims within warranty time, which are based on material malfunctions the producer offers free replacement. The method of return of malfunctioned module, together with description, can be arranged with our authorized representative. Warranty does not include damage due to transport or because of unconsidered corresponding regulations of the country, where the module is installed.

This device must be connected properly by the provided connection scheme in this manual. Misconnections may result in device damage, fire or personal injury.

Hazardous voltage in the device can cause electric shock and may result in personal injury or death.

**NEVER SERVICE THIS PRODUCT YOURSELF!**

This device must not be installed in the systems critical for life (e.g. medical devices, aircrafts, etc.).

If the device is used in a manner not specified by the manufacturer, the degree of protection provided by the equipment may be impaired.

Waste electrical and electronic equipment (WEEE) must be collected separately!

LONGO LPC-2 complies to the following standards:

- EMC: EN 61000-6-3:2007 + A1:2011, EN 61000-6-1:2007, EN 61000-3-2:2006 + A1:2009 + A2: 2009, EN 61000-3-3:2013

Smarteh d.o.o. operates a policy of continuous development. Therefore we reserve the right to make changes and improvements to any of the products described in this manual without any prior notice.

**MANUFACTURER:**

SMARTEH d.o.o.  
Poljubinj 114  
5220 Tolmin  
Slovenia



# Index

## Longo programmable controller LPC-2.MM2

---

1 ABBREVIATIONS.....	1
2 DESCRIPTION.....	2
3 FEATURES.....	3
4 INSTALLATION.....	4
4.1 Connection scheme.....	4
4.2 Mounting instructions.....	7
4.3 Module labeling.....	9
5 TECHNICAL SPECIFICATIONS.....	10
6 PROGRAMMING GUIDE.....	11
6.1 Basic functionalities.....	11
6.2 WiFi configuration.....	14
7 SPARE PARTS.....	16
8 CHANGES .....	17
9 NOTES.....	18



## 1 ABBREVIATIONS

---

SOM	System on module
ARM	Advanced RISC machines
OS	Operating system
TCP	Transmission control protocol
SSL	Secure sockets layer
IEC	International electrotechnical commission
CAN	Controller area network
COM	Communication
USB	Universal serial bus
USB OTG	Universal serial bus On the go
PLC	Programmable logic controller
LED	Light emitting diode
RAM	Random access memory
NV	Non volatile
PS	Power supply
RTU	Remote terminal unit
RTC	Real time clock
IDE	Integrated development environment
FBD	Function block diagram
LD	Ladder diagram
SFC	Sequential function chart
ST	Structured text
IL	Instruction list



## 2 DESCRIPTION

---

LPC-2.MM2 Smarteh flagship main module modular PLC offers improved performance, scalability and a wide range of new features within a single compact SOM based package. Simple and innovative concept, where most competitors require multiple products to deliver similar functionality. The main module based on ARM architecture processor running Linux based OS adds more computing power, more control and additional interface connection offering capability for future core SOM module upgrades without hardware changes.

In addition, LPC-2.MM2 is designed to connect additional input and output modules on the right side, to the connector K1.

LPC-2.MM2 has an integrated USB programming and debugging port, connection for Smarteh intelligent peripheral modules, two Ethernet ports and WiFi connectivity that all can be used as a programming and debugging port, as a Modbus TCP/IP Master and/or Slave device and as BACnet IP (B-ASC). Two Ethernet ports support Ethernet daisy chain fail-safe functionality by using integrated Ethernet switch. In the case of LPC-2.MM2 and/or local power supply failure, two Ethernet ports will be physically disconnected from the LPC-2.MM2 Ethernet driver and will connect to each other directly. LPC-2.MM2 is also equipped with RS-485 port for Modbus RTU Master or Slave communication with other Modbus RTU equipment.

Hardware configuration is done using Smarteh IDE programming software, used to design user configuration by selecting from a wide range of modules with up to 7 modules in a single configuration.

This software also provides you with a simple entry in the IEC programming languages such as:

- Instruction List (IL)
- Function Block Diagram (FBD)
- Ladder Diagram (LD)
- Structured Text (ST)
- Sequential Function Chart (SFC).

This provides a large number of operators such as:

- Logic operators such as AND, OR, ...
- Arithmetic operators such as ADD, MUL, ...
- Comparison operators such as <, =, >
- Other ...

Programming software is used to create, debug, test and document a project. Functions for analog processing, closed-loop control and function blocks such as timers and counters simplify programming.



### 3 FEATURES

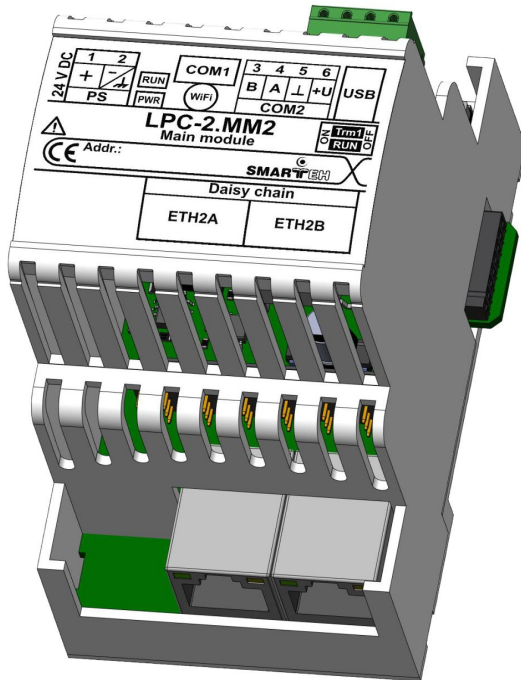

Figure 1: LPC-2.MM2 module

**Table 1: Features**

Real Time Linux OS ARM based main module
Two Ethernet ports with integrated Ethernet switch and fail-safe daisy chain functionality
WiFi connectivity
Ethernet & WiFi connectivity for debugging and application transfer, Modbus TCP/IP Slave (server) and/or Master (client) functionality, BACnet IP (B-ASC), web server and SSL certificate
Wi-Fi connector for external antenna
USB port for debugging and application transfer, USB OTG
Modbus RTU Master or Slave
SmarteH bus for connection with LPC-2 SmarteH intelligent peripheral modules
Remote access and application transfer
RTC and 512 kB non-volatile memory with super capacitor for needed energy storage
Status LEDs



## 4 INSTALLATION

### 4.1 Connection scheme

Figure 2: Connection scheme

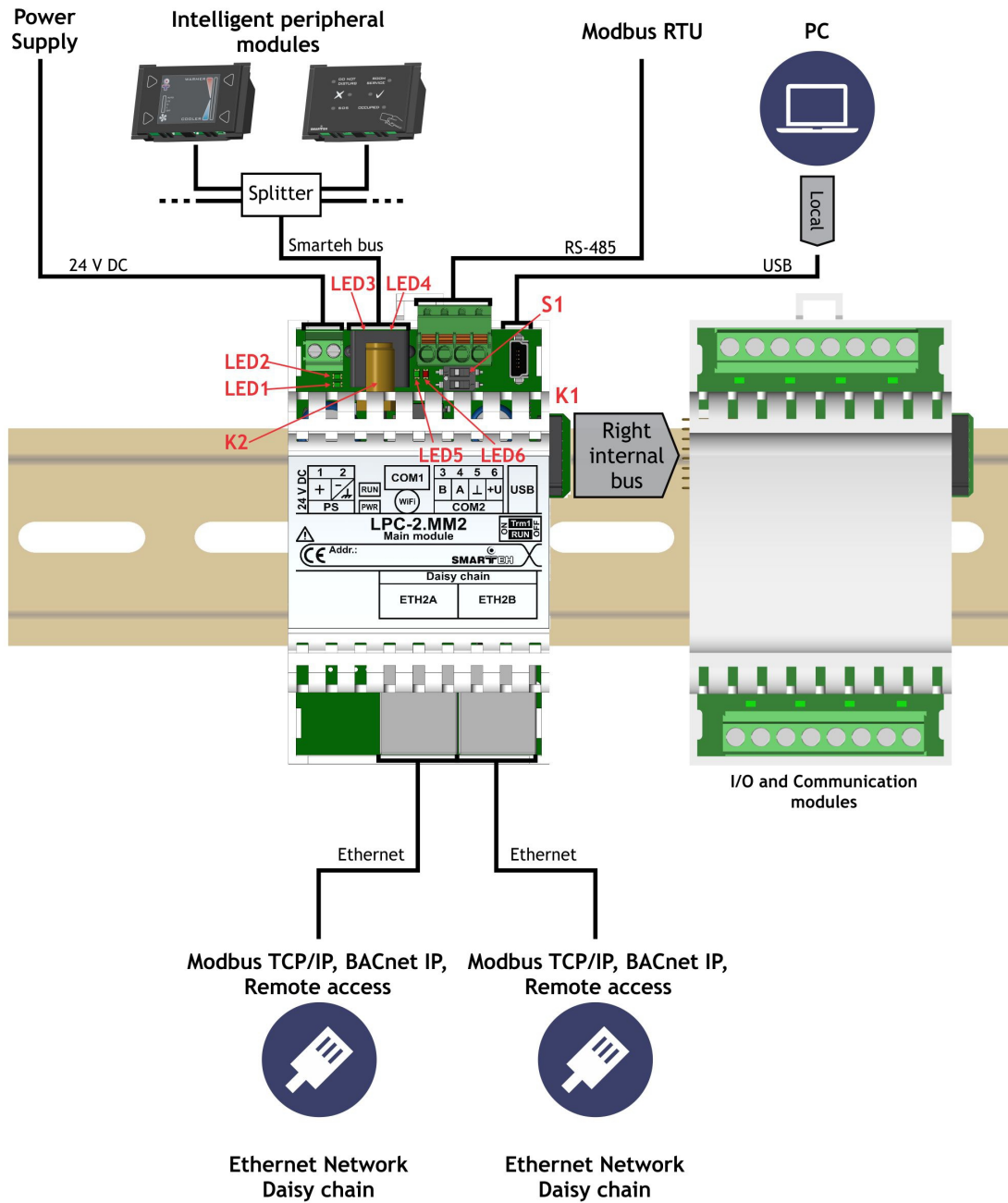





**Table 2: Power supply**

PS.1	+	Power supply, 20 .. 28 V DC, 2 A
PS.2	— / 	EGND

**Table 3: COM1 Smarteh bus**

COM1.1	N.C.	
COM1.2		GND
COM1.3	+U	Power supply output, 15V
COM1.4	RS-485 (A) Smarteh bus	0 .. 3.3 V
COM1.5	RS-485 (B) Smarteh bus	
COM1.6	N.C.	

**Table 4: COM2 RS-485<sup>1</sup>**

COM2.3	RS-485 (B) Modbus RTU	0 .. 3.3 V
COM2.4	RS-485 (A) Modbus RTU	
COM2.5		GND
COM2.6	+U	Power supply output, 15V

**Table 5: Internal bus**

K1	Data & DC power supply	Connection to comm. module(s)
----	------------------------	-------------------------------

**Table 6: WiFi**

K2	WiFi antenna connector	SMA
----	------------------------	-----

**Table 7: USB and Ethernet**

USB	USB	mini B type, device mode or host mode, USB On-The-Go
Ethernet	ETH2A	RJ-45 shielded, daisy chain functionality
Ethernet	ETH2B	RJ-45 shielded, daisy chain functionality

**Table 8: Switches**

S1.1	COM2 RS-485 termination (Trm)	ON: RS-485 channel is internally terminated with 1.2 kΩ OFF: no internal termination present
S1.2	Operation mode (RUN)	ON: PLC in normal operational mode (RUN) OFF: PLC application not running (STOP)

<sup>1</sup> Different protocols like Modbus RTU Master can be selected inside Smarteh IDE. Wires connected to the module must have cross sectional area at least 0.14 mm<sup>2</sup>. Use twisted-pair cables of type CAT5+ or better, shielding is recommended. Minimum temperature rating of wire insulation must be 85 °C.



**Table 9: LEDs**

LED1: green	RUN, Application running	ON: application is running OFF: application is stopped or PLC in boot mode
LED2: green	PWR, Power supply status	ON: PLC is powered on OFF: PLC has no power supply Blink: Short circuit
LED3: green	COM1 RS-485 Tx status	Blink: OK Off: no answer On: A and/or B line in shortcut
LED4: red	COM1 RS-485 Rx status	Blink: OK Off: no communication from Master On: A and/or B line in shortcut
LED5: green	COM2 RS-485 Tx status	Blink: OK Off: no answer On: A and/or B line in shortcut
LED6: red	COM2 RS-485 Rx status	Blink: OK Off: no communication from Master On: A and/or B line in shortcut



## 4.2 Mounting instructions

**Figure 3: Housing dimensions**

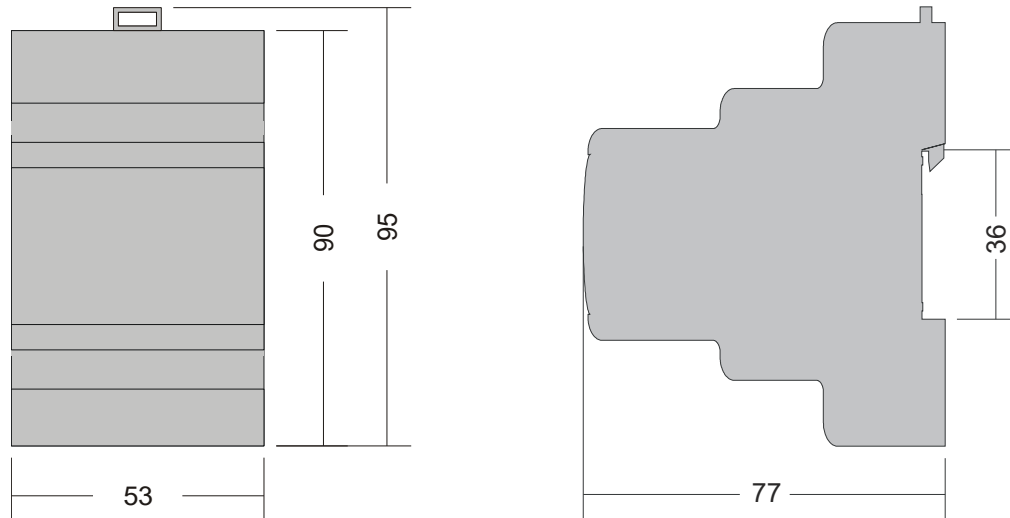

Dimensions in millimeters.



**RECOMMENDATION ON SWITCH OR CIRCUIT-BREAKER PROTECTION:** There should be two poles main switch in the installation in order to switch off the module. The switch must meet the requirements of standard IEC60947-1 and have a nominal value at least 6 A. The switch or circuit-breaker should be within easy reach of the operator. It must be used as the disconnected device for the equipment.

**RATING AND CHARACTERISTICS OF FUSES:** LPC-2.MM2 main module must be connected with 4 A circuit breaker in Live and Neutral conductor. It is class I unit and must be permanently connected to Protective Earth. The units are permanently connected to the Mains.

All connections, module attachments and assembling must be done while module is not connected to the main power supply. Wires connected to the module must have cross sectional area at least 0.75 mm<sup>2</sup>. Minimum temperature rating of wire insulation must be 85 °C.

The modules must be installed in enclosure with no openings. Enclosure must provide electrical and fire protection which shall withstand dynamic test with 500 g steel sphere from distance is 1.3 m and also static test 30 N. When installed in enclosure, only authorized person can have a key to open it.



**Mounting instructions:**

1. Switch OFF main power supply.
2. Mount module to the provided place inside an electrical panel (DIN EN50022-35 rail mounting).
3. Mount other IO modules (if required). Mount each module to the DIN rail first, then attach modules together through K1 connector.
4. Connect needed input, output and communication wires.
5. Switch ON main power supply.
6. Dismount in reverse order. For mounting/dismounting modules to/from DIN rail a free space of at least one module must be left on the DIN rail.

**Figure 4: Minimum clearances**

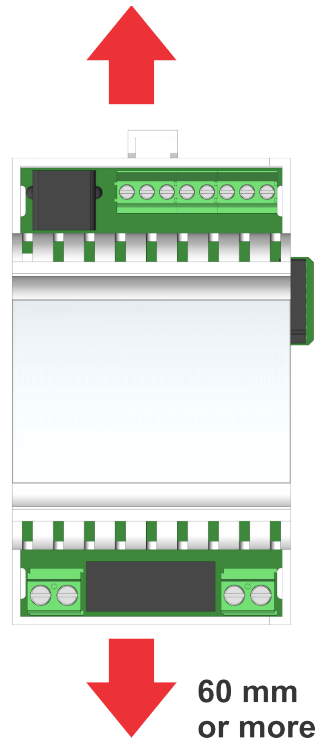

The clearances above must be considered before module mounting.



## 4.3 Module labeling

**Figure 5: Label**

Label (sample):

**XXX-N.ZZZ**  
P/N: AAABBBCCDDDEEE  
S/N: SSS-RR-YYXXXXXXXXXX  
D/C: WW/YY

### *Label description:*

1. **XXX-N.ZZZ** - full product name.
  - **XXX-N** - Product family
  - **ZZZ** - product
2. **P/N: AAABBBCCDDDEEE** - part number.
  - **AAA** - general code for product family,
  - **BBB** - short product name,
  - **CCDDD** - sequence code,
    - **CC** - year of code opening,
    - **DDD** - derivation code,
  - **EEE** - version code (reserved for future HW and/or SW firmware upgrades).
3. **S/N: SSS-RR-YYXXXXXXXXXX** - serial number.
  - **SSS** - short product name,
  - **RR** - user code (test procedure, e.g. Smarteh person xxx),
  - **YY** - year,
  - **XXXXXXXXXX**- current stack number.
4. **D/C: WW/YY** - date code.
  - **WW** - week and
  - **YY** - year of production.

### *Optional*

1. **MAC**
2. **Symbols**
3. **WAMP**
4. **Other**



## 5 TECHNICAL SPECIFICATIONS

**Table 10: Technical specifications**

Rated power supply PS	24 V DC, 2A
Operational power supply PS	20 .. 28 V DC
Power consumption PS	up to 24 W depending on additional modules connected to main module
Connection type for PS	screw type connector for stranded wire 0.75 to 1.5 mm <sup>2</sup>
Connection type for COM1	RJ-12 6/4
Connection type for COM2	disconnectable spring type connectors for stranded wire 0.14 to 1.5 mm <sup>2</sup>
COM1 Smarteh bus	non isolated
COM2 RS-485 port	non isolated, 2 wire
Ethernet 2A & Ethernet 2B	RJ-45, 10/100T IEEE 802.3 Daisy chain functionality, fail-safe operation. Integrated 10/100 Ethernet Switch
WiFi	IEEE 802.11 b/g/n, SMA female connector
USB	mini B type, device mode or host mode, USB On-The-Go, high-speed/full-speed
RTC	capacitor backed up with retention cca. 14 days
Operating system	Linux
CPU	i.MX6 Single (ARM® Cortex™-A9) @ 1GHz
RAM	1 GB DDR3
Flash	4 GB eMMC 8bits (MLC type)
NV RAM	512 kB, capacitor backed up with retention cca. 14 days
Dimensions (L x W x H)	90 x 53 x 77 mm
Weight	170 g
Ambient temperature	0 to 50 °C
Ambient humidity	max. 95 %, no condensation
Maximum altitude	2000 m
Mounting position	vertical
Transport and storage temperature	-20 to 60 °C
Pollution degree	2
Over-voltage category	II
Electrical equipment	class II (double insulation)
Protection class	IP 30



## 6 PROGRAMMING GUIDE

---

This chapter is intended to offer the programmer additional information about some of the functionalities and units integrated in this module.

### 6.1 Basic functionalities

#### RTC unit

For RTC back-up and for Retain variables there is Super Capacitor instead of battery integrated inside PLC. This way, replacement of the discharged battery is avoided. The Retention time is minimum 14 days from the power down. RTC time provides date and time information.

#### Ethernet

Both Ethernet ports can be used as a programming and debugging port, as a Modbus TCP/IP Master and/or Slave device and as BACnet IP (B-ASC). Two Ethernet ports support Ethernet daisy chain fail-safe functionality by using an integrated Ethernet switch. In the case of LPC-2.MM2 and/or local power supply failure, two Ethernet ports will be physically disconnected from the LPC-2.MM2 Ethernet driver and will be connected to each other directly.

#### WiFi

WiFi port can be used as a programming and debugging port, as a Modbus TCP/IP Master and/or Slave device and as BACnet IP (B-ASC).

#### Modbus TCP/IP master unit

When configured for Modbus TCP/IP Master / Client mode, the LPC-2.MM2 functions as a master device, controlling the communications with other slave devices such as sensors, inverters, other PLCs, etc. LPC-2.MM2 sends Modbus TCP/IP commands to and receives Modbus TCP/IP responses from the slave units.

Following commands are supported:

- 01 - Read Coil Status
- 02 - Read Input Status
- 03 - Read Holding Registers
- 04 - Read Input Registers
- 05 - Write Single Coil
- 06 - Write Single Register
- 15 - Write Multiple Coils
- 16 - Write Multiple Registers

Note: each of this command can read/write up to 10000 addresses.



### Modbus TCP/IP slave unit

Modbus TCP slave has 10000 addresses in each memory section:

Coils:	00000 to 09999
Discrete inputs:	10000 to 19999
Input register:	30000 to 39999
Holding registers:	40000 to 49999

Supports up to 5 connections to the slave units (defined with MaxRemoteTCPClient parameter).  
Highest scan rate is 100 ms.

### Modbus RTU master unit

When configured for Modbus RTU Master mode, the LPC-2.MM2 functions as a master device, controlling the communications with other slave devices such as sensors, inverters, other PLCs, etc. LPC-2.MM2 sends Modbus RTU commands to and receives Modbus RTU responses from the slave devices.

Following commands are supported:

- 01 - Read Coil Status
- 02 - Read Input Status
- 03 - Read Holding Registers
- 04 - Read Input Registers
- 05 - Write Single Coil
- 06 - Write Single Register
- 15 - Write Multiple Coils
- 16 - Write Multiple Registers

Note: each of this commands can read/write up to 246 bytes of data. For analog (Input and Holding registers) this means 123 values, while for digital (Statuses and Coils) this means 1968 values. When higher quantity of data is required, LPC-2.MM2 can execute up to 32 same or different supported commands simultaneous.

Physical layer: RS-485

Supported baud rates: 9600, 19200, 38400, 57600 and 115200bps

Parity: None, Odd, Even.

Stop bit: 1

### Modbus RTU slave unit

Modbus TCP slave has 1024 addresses in each memory section:

Coils:	00000 to 01023
Discrete inputs:	10000 to 11023
Input register:	30000 to 31023
Holding registers:	40000 to 41023

Highest scan rate is 100 ms.

### SmarteH RS485 bus for connectivity with LPC-2 system

Port COM1 is used for communication with LPC-2 slave modules. All communication settings are configured in SmarteHIDE software program.





### **BACnet IP unit**

When configured for BACnet IP (B-ACS), following commands are supported:

#### Data Sharing

- ReadProperty-B (DS-RP-B)
- WriteProperty-B (DS-WP-B)

#### Device and Network Management

- Dynamic Device Binding-B (DM-DDB-B)
- Dynamic Object Binding-B (DM-DOB-B)
- Device Communication Control-B (DM-DCC-B)
- Time Synchronization-B (DM-TS-B)
- UTCTimeSynchronization-B (DM-UTC-B)

For more information, please contact the producer.

### **RUN Switch**

**Run:** Status RUN status LED “on” indicate that the user graphical application is up and user program is running.

**Stop:** When the switch is turn to STOP state, the RUN status LED is “off” and application is stopped.

### **PLC task cycle time**

Main PLC task interval (under Project tab -> Resource → Tasks → Interval) time is not recommended to be set lower than 50 ms.



## 6.2 WiFi configuration

1. Connect module to the PC via USB connector and switch ON power supply.
2. Using web browser, type default IP address 192.168.45.1 and port 8009.
3. Click on “Settings”.

**Figure 6: Web interface**

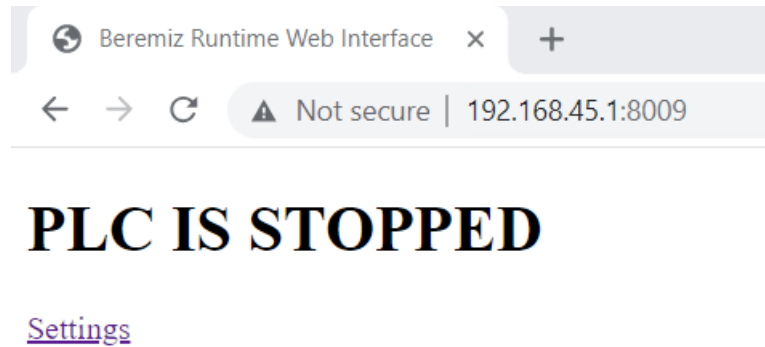

4. The Settings page opens. In the “Network Settings for eth() interface (wired)” section select “Disabled”, from the “Configuration type” drop-down menu.
5. Click on “Set” at the bottom of that section.
6. Then in the “Network Settings for wlan() interface (wireless)” section set the parameters of the wireless network to which you want to connect: “Configuration type”, “Authentication type”, “Network name” and “Password”.
7. Click on “Set” at the bottom of that section.



**Figure 7: Web interface settings**

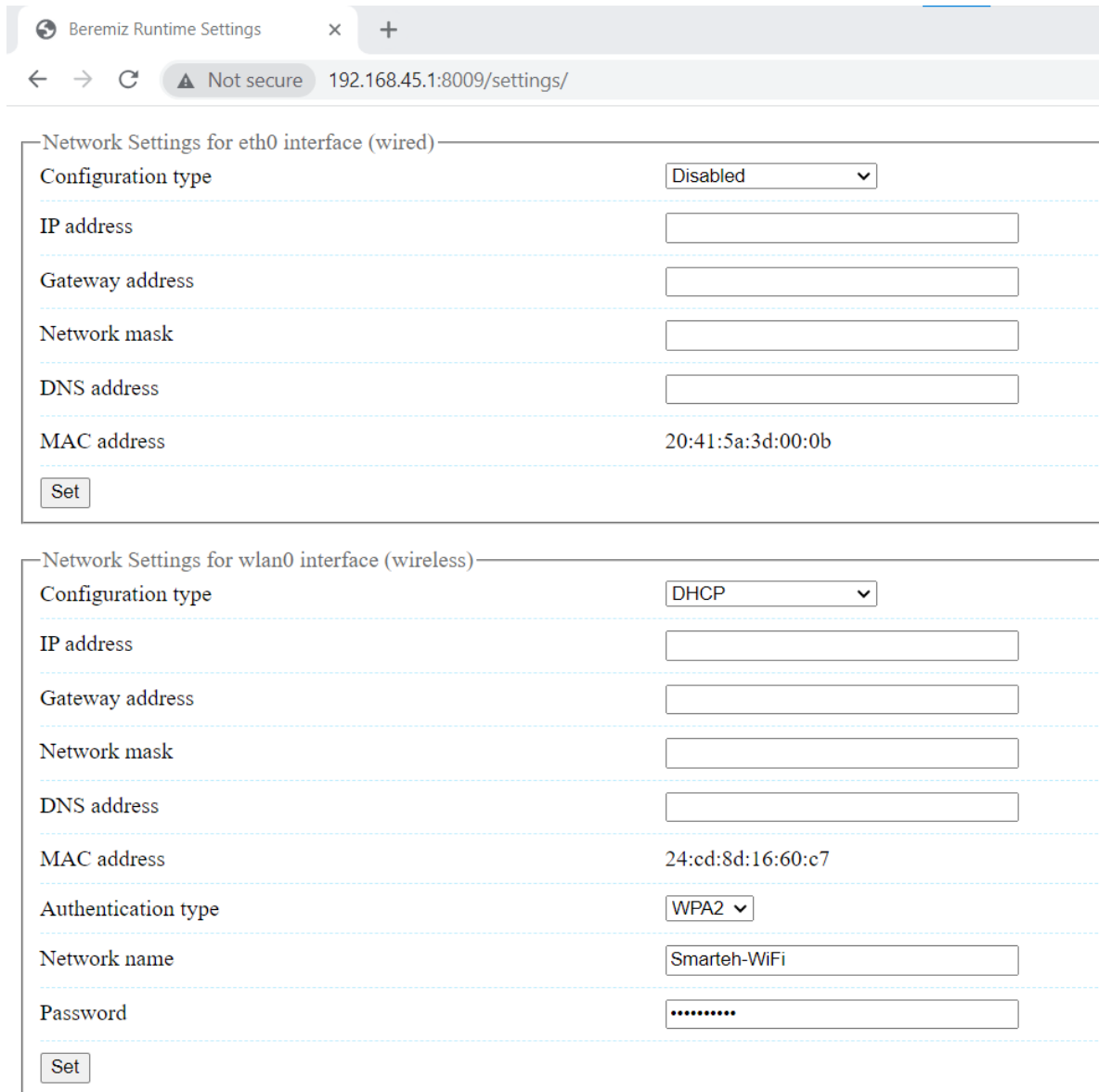

The screenshot shows a web browser window with the following details:

- Browser tab: Beremiz Runtime Settings
- Address bar: Not secure 192.168.45.1:8009/settings/
- Section 1: Network Settings for eth0 interface (wired)
  - Configuration type: Disabled
  - IP address: [Empty text box]
  - Gateway address: [Empty text box]
  - Network mask: [Empty text box]
  - DNS address: [Empty text box]
  - MAC address: 20:41:5a:3d:00:0b
  - Set button: [Set]
- Section 2: Network Settings for wlan0 interface (wireless)
  - Configuration type: DHCP
  - IP address: [Empty text box]
  - Gateway address: [Empty text box]
  - Network mask: [Empty text box]
  - DNS address: [Empty text box]
  - MAC address: 24:cd:8d:16:60:c7
  - Authentication type: WPA2
  - Network name: Smarteh-WiFi
  - Password: [Masked with dots]
  - Set button: [Set]



## 7 SPARE PARTS

---

For ordering spare parts following Part Numbers should be used:

LPC-2.MM2 Main module	
LPC-2.MM2	P/N: 225MM223001001

---



## 8 CHANGES

---

The following table describes all the changes to the document.

Date	V.	Description
19.12.23	1	The initial version, issued as <i>LPC-2.MM2 User Manual</i> .



## 9 NOTES

---

