



SMARTEH[®]
LIVING SYSTEMS

USER MANUAL

- ▶ Longo programmable controller
LPC-2.ID3V
Card Reader module

Version 3

Written by SMARTEH d.o.o.
Copyright © 2016, SMARTEH d.o.o.

User Manual

Document Version: 3
November, 2016



STANDARDS AND PROVISIONS: Standards, recommendations, regulations and provisions of the country in which the devices will operate, must be considered while planning and setting up electrical devices. Work on 100 .. 240 V AC network is allowed for authorized personnel only.

DANGER WARNINGS: Devices or modules must be protected from moisture, dirt and damage during transport, storing and operation.

WARRANTY CONDITIONS: For all modules LONGO LPC-2 - if no modifications are performed upon and are correctly connected by authorized personnel - in consideration of maximum allowed connecting power, warranty of 24 months is valid from the date of sale to the end buyer, but not more than 36 months after delivery from Smarteh. In case of claims within warranty time, which are based on material malfunctions the producer offers free replacement. The method of return of malfunctioned module, together with description, can be arranged with our authorized representative. Warranty does not include damage due to transport or because of unconsidered corresponding regulations of the country, where the module is installed.

This device must be connected properly by the provided connection scheme in this manual. Misconnections may result in device damage, fire or personal injury.

Hazardous voltage in the device can cause electric shock and may result in personal injury or death.

NEVER SERVICE THIS PRODUCT YOURSELF!

This device must not be installed in the systems critical for life (e.g. medical devices, aircrafts, etc.).

If the device is used in a manner not specified by the manufacturer, the degree of protection provided by the equipment may be impaired.

Waste electrical and electronic equipment (WEEE) must be collected separately!

LONGO LPC-2 complies to the following standards:

- EMC: EN 61000-6-3:2007 + A1:2011, EN 61000-6-1:2007, EN 61000-3-2:2006 + A1:2009 + A2: 2009, EN 61000-3-3:2013
- LVD: IEC 61010-1:2010 (3rd Ed.), IEC 61010-2-201:2013 (1st Ed.)

Smarteh d.o.o. operates a policy of continuous development. Therefore we reserve the right to make changes and improvements to any of the products described in this manual without any prior notice.

MANUFACTURER:

SMARTTEH d.o.o.
Poljubinj 114
5220 Tolmin
Slovenia



Index

Longo programmable controller LPC-2.ID3V

1 ABBREVIATIONS.....1

2 DESCRIPTION.....2

3 FEATURES.....3

4 OPERATION.....4

 4.1 Operational modes.....4

 4.2 Parameters.....4

5 INSTALLATION.....6

 5.1 Connection scheme.....6

 5.2 Mounting frame selection.....8

 5.3 Mounting instructions.....9

 5.4 Module labeling.....10

6 TECHNICAL SPECIFICATIONS.....11

7 SPARE PARTS.....12

8 CHANGES13

9 NOTES.....14



1 ABBREVIATIONS

Sorted by order of appearance in document:

- RFID Radio frequency identification
- LED Light emitting diode



2 DESCRIPTION

LPC-2.ID3V RFID reader is intended to be used as an identity verification device at room entrance.

When RFID tag (key-card) is approached to the reader and its code is successfully read out, the green LED blinks and a short buzzer is generated. In case key-card for correspondent room is valid, the green LED blinks again and a short buzzer is generated. Other devices can be activated at this event like door lock opening, turning light on,... (SmarteH IDE can be used for function logic). If key-card number is not valid, the red LED blinks and a longer buzzer is generated.

LPC-2.ID3V module can be modified on customer request: custom front label, push buttons added, LEDs added, housing color. Please contact manufacturer for more information.

LPC-2.ID3V is controlled and powered from the main module (e.g., LPC-2.MC8, LPC-2.MC9) via Smarteh bus.



3 FEATURES



Figure 1: LPC-2.ID3V

Table 1: Features

RFID reader
OK “ ✓ ” LED
Fault “ X ” LED
Power LED
Communication error LED



4 OPERATION

LPC-2.ID3V can be in one of two operational modes - normal or error. When LPC-2.ID3V is in normal mode, module parameters can be read or written via Smarteh IDE software.

4.1 Operational modes

Normal

Communication with the main module is working. Only blue “PWR” LED4 is turned on.

Error

In case of communication fault, red “ERR” LED3 will turn on.

4.2 Parameters

If parameter is set to logical “1”, is considered to be active, enabled or set. If parameter has logical value “0” is considered to be inactive, disabled or cleared.

Parameter can be a command or feedback. When parameter is marked as feedback it means that LPC-2.ID3V is sending information to the main module. On the other hand, command represents request from the main module to the LPC-2.ID3V.

Command:

ID Fault [*oFault*]: Command for rejecting authorization of RFID code.

Type: BOOL

Raw to engineering data: “0” → Off
 “1” → RFID code rejected

ID OK [*oOk*]: Command for accepting authorization of RFID code.

Type: BOOL

Raw to engineering data: “0” → Off
 “1” → RFID code accepted

Buzzer [*oBuzz*]: While this command is active, buzzer is active.

Type: BOOL

Raw to engineering data: “0” → Buzzer off
 “1” → Buzzer on

'Fault' ID LED [*oFaultLD*]: While this command is active, fault LED2 is set.

Type: BOOL

Raw to engineering data: “0” → Fault LED2 off
 “1” → Fault LED2 on

'OK' ID LED [*oOkLd*]: While this command is active, OK LED1 is set.

Type: BOOL

Raw to engineering data: “0” → OK LED1 off
 “1” → OK LED1 on

Feedback:

RFID ID received Word1 [*iIDW1*]: Upper (most significant) third of RFID code.

Type: WORD

Raw to engineering data: 0 .. 65535 → 0 .. 65535

RFID ID received Word2 [*iIDW2*]: Middle third of RFID code.



Type: WORD

Raw to engineering data: 0 .. 65535 → 0 .. 65535

RFID ID received Word3 [*iIDW3*]: Lower (least significant) third of RFID code.

Type: WORD

Raw to engineering data: 0 .. 65535 → 0 .. 65535

New ID received [*iIDNew*]: When new RFID tag is recognized, this status is set active for 10 seconds or till authorization command is received (*oOK* or *oFault*).

Type: BOOL

Raw to engineering data: “0” → Off

“1” → New ID

Communication status [*iComm*]: Normal state is “1”. If “0”, there is communication error or no communication established.

Type: BOOL

Raw to engineering data: “0” → Error

“1” → OK



5 INSTALLATION

5.1 Connection scheme

Figure 2: Connection scheme

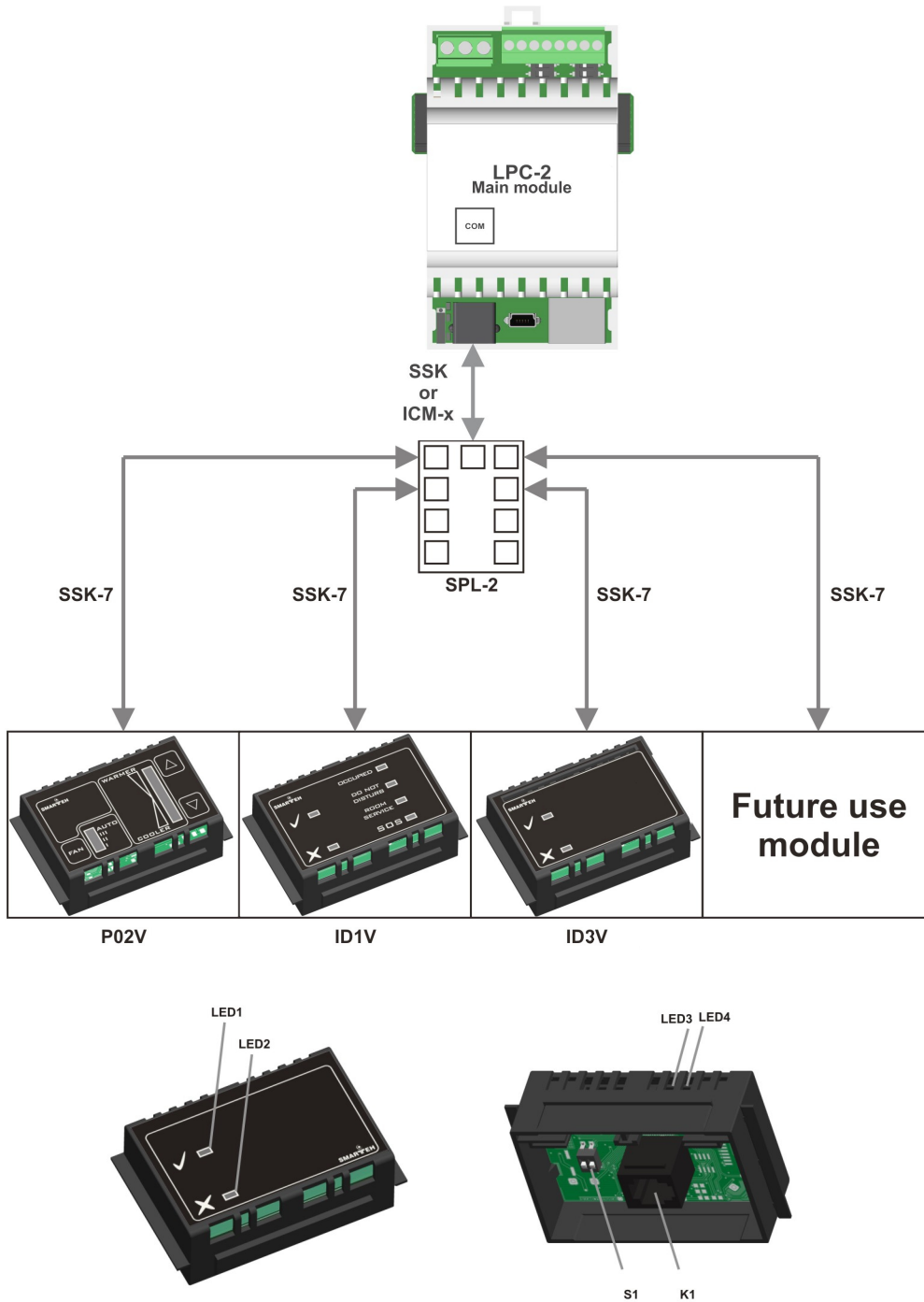

Table 2: K1

K1.1	GND	Ground
K1.2	15 .. 24 V DC	Power supply input
K1.3	RS-485 A	Data receive/send line A
K1.4	RS-485 B	Data receive/send line B

Table 3: LEDs & Buttons

LED1: green	OK “ J ”	ON: RFID key standard OK and ID card number valid OFF: no tag in proximity
LED2: red	Fault “ X ”	ON: RFID key standard NOK or ID card number wrong OFF: no tag in proximity
LED3: red	Communication	ON: RS-485 communication fault OFF: RS-485 communication OK
LED4: blue	Power supply	ON: power supply OK OFF: power supply missing or power off

Table 4: S1

RS-485 ADDRESS	Switch 1	Switch 2
0	OFF	OFF
1	OFF	ON
2	ON	OFF
3	ON	ON



5.2 Mounting frame selection

Frame, suitable for ID3V module insertion, should be modular one at least 3 gang wide. Be careful to have corresponding flush-mounting box provided on the place where module will be positioned.

SmarteH has verified following lines to be compatible with LPC-2.ID3V module:

- Bticino - Living, Light
- Gewiss - Playbus, System
- Vimar - Plana, Idea
- Tem
- Master

Frames of other vendors most probably suits as well, but they were not verified by SmarteH. Before installation verify compatibility of non listed frames.

Module housing has a fin on each side, which can be easily removed with knife cutter or pliers. This adaptation enables housing to be build in various frame formats. With regard to frame used you may remove fin for housing to fit in.

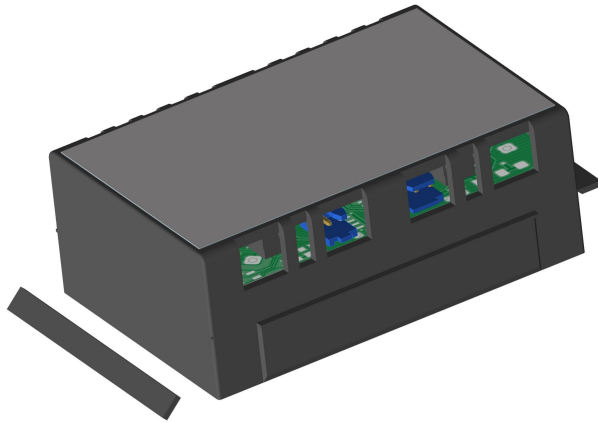
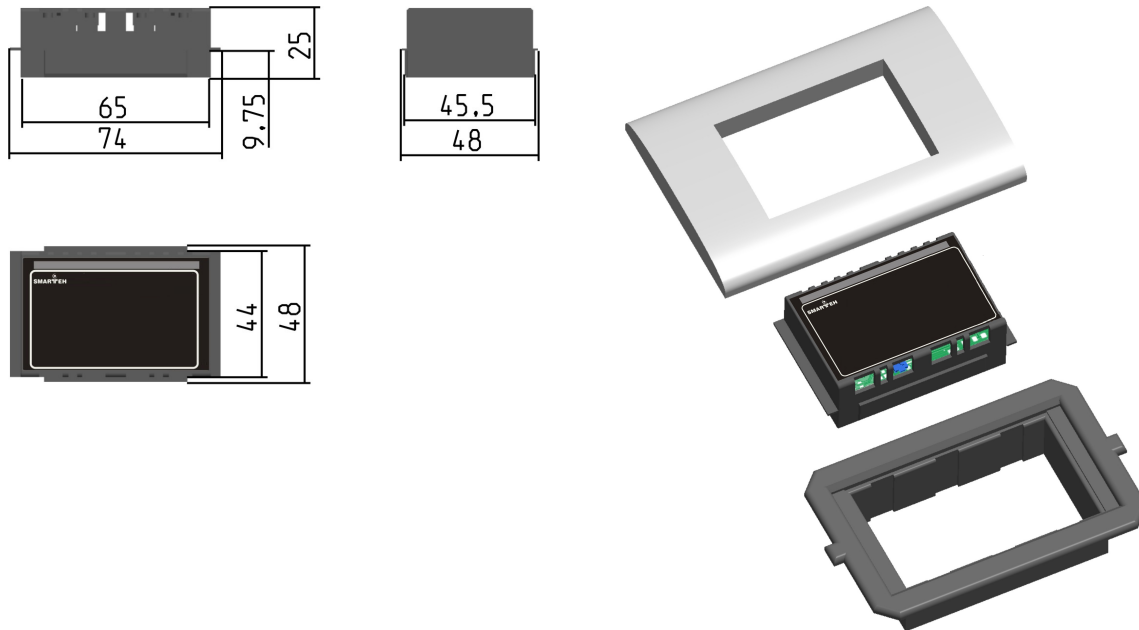

Figure 3: Fin removing



5.3 Mounting instructions

Figure 4: Housing dimensions



Dimensions in millimeters.



All connections, module attachments and assembling must be done while module is not connected to the main power supply.

Several RFID panels should not be mounted close to each other. Minimum distance to next panel is at least 30 cm. This restriction also applies in case of mounting panels on both sides of the same wall. Adequate shielding material and provisions could be used to avoid interference between panels. Mounting of RFID panels into conductive, metal frames, is not allowed.

RFID panel should not be positioned close to conductive areas.

Mounting instructions:

1. Set the correct RS-485 address (S1 switch) for LPC-2.ID3V (refer to the Table 4).
2. Connect interconnection cable to the connector K1. Max. allowed tractive force is 30 N.
3. Put the LPC-2.ID3V in mounting frames.
4. Cover LPC-2.ID3V with cover plate.

LPC-2.ID3V is connected to the main module with interconnection cable (e.g. SSK, ICM-7) which must be ordered together with LPC-2.ID3V module. When more modules are connected to the main module, splitter (e.g. SPL-2) is also required (Figure 2). Signal wires must be installed separately from power and high voltage wires in accordance with general industry electrical installation standard.

NOTE: Signal wires must be installed separately from power and high voltage wires in accordance with general industry electrical installation standard.



5.4 Module labeling

Table 5: Labels

Label 1 (sample):

LPC-2.ID3V
 P/N:225ID308V01001
 D/C: 40/08

Label 2 (sample):

S/N: ID3V-S9-0800000003

Label 1 descriptions:

1. **LPC-2.ID3V** is the full product name.
2. **P/N: 225ID308V01001** is the part number.
 - **225** - general code for product family,
 - **ID3** - short product name,
 - **08V01** - sequence code,
 - **08** - year of code opening,
 - **V01** - derivation code,
 - **001** - version code (reserved for future HW and/or SW firmware upgrades).
3. **D/C: 40/08** is the date code.
 - **40** - week and
 - **08** - year of production.

Label 2 descriptions:

1. **S/N: ID3V-S9-0800000003** is the serial number.
 - **ID3V** - short product name,
 - **S9** - user code (test procedure, e.g. Smarteh person xxx),
 - **0800000003** - year and current stack code,
 - **08** - year (last two cyphers),
 - **00000003** - current stack number; previous module would have the stack number 00000002 and the next one 00000004.



6 TECHNICAL SPECIFICATIONS

Table 6: Technical specifications

Power supply	from main module
Interconnection connector type	RJ-12 6/6
Power consumption	1.5 W
RFID type	EM4100, 125 kHz, Manchester 64, read only
Max. reading distance	2 cm
Dimensions (W x H x D)	74 x 48 x 25 mm
Weight	30 g
Ambient temperature	0 to 50 °C
Ambient humidity	max. 95 %, no condensation
Maximum altitude	2000 m
Mounting position	vertical
Transport and storage temperature	-20 to 60 °C
Pollution degree	2
Protection class	IP 20



7 SPARE PARTS

For ordering spare parts following Part Numbers should be used:

LPC-2.ID3V RFID card access, black	
LPC-2.ID3V	P/N: 225ID308V02003
LPC-2.ID3V RFID card access, white	
LPC-2.ID3V	P/N: 225ID308V01003
Interconnection cable	
ICM-x	P/N: 203ICMxxxxxxxxx
Splitter	
SPL-1 (1/2)	P/N: 206SPL04001001



8 CHANGES

The following table describes all the changes to the document.

Date	V.	Description
17.11.16	3	General update.
01.07.12	2	CGP General update.
06.03.09	1	The initial version, issued as <i>LPC-2.ID3V module User Manual</i> .





9 NOTES

