



**SMARTEH**<sup>®</sup>  
LIVING SYSTEMS

# USER MANUAL

- ▶ Longo programmable controller  
LPC-2.DI6  
Digital Input module

Version 5

Written by SMARTEH d.o.o.  
Copyright © 2012, SMARTEH d.o.o.

User Manual

Document Version: 005  
July 1, 2012



**STANDARDS AND PROVISIONS:** Standards, recommendations, regulations and provisions of the country in which the devices will operate, must be considered while planning and setting up electrical devices. Work on 100 .. 240 V AC network is allowed for authorized personnel only.

**DANGER WARNINGS:** Devices or modules must be protected from moisture, dirt and damage during transport, storing and operation.

**WARRANTY CONDITIONS:** For all modules LONGO LPC-2 - if no modifications are performed upon and are correctly connected by authorized personnel - in consideration of maximum allowed connecting power, warranty of 24 months is valid from the date of sale to the end buyer, but not more than 36 months after delivery from Smarteh. In case of claims within warranty time, which are based on material malfunctions the producer offers free replacement. The method of return of malfunctioned module, together with description, can be arranged with our authorized representative. Warranty does not include damage due to transport or because of unconsidered corresponding regulations of the country, where the module is installed.

This device must be connected properly by the provided connection scheme in this manual. Misconnections may result in device damage, fire or personal injury.

Hazardous voltage in the device can cause electric shock and may result in personal injury or death.

**NEVER SERVICE THIS PRODUCT YOURSELF!**

This device must not be installed in the systems critical for life (e.g. medical devices, aircrafts, etc.).

If the device is used in a manner not specified by the manufacturer, the degree of protection provided by the equipment may be impaired.

Waste electrical and electronic equipment (WEEE) must be collected separately!

LONGO LPC-2 complies to the following standards:

- EMC: EN 61000-6-3:2007 + A1:2011, EN 61000-6-1:2007, EN 61000-3-2:2006 + A1:2009 + A2: 2009, EN 61000-3-3:2013
- LVD: IEC 61010-1:2010 (3<sup>rd</sup> Ed.), IEC 61010-2-201:2013 (1<sup>st</sup> Ed.)

Smarteh d.o.o. operates a policy of continuous development. Therefore we reserve the right to make changes and improvements to any of the products described in this manual without any prior notice.

**MANUFACTURER:**

SMARTEH d.o.o.  
Poljubinj 114  
5220 Tolmin  
Slovenia



Index

**Longo programmable controller LPC-2.DI6**

---

1 DESCRIPTION.....1

2 FEATURES.....2

3 INSTALLATION.....3

    3.1 Connection scheme.....3

    3.2 Mounting instructions.....5

    3.3 Module labeling.....6

4 TECHNICAL SPECIFICATIONS.....7

5 CHANGES .....8

6 NOTES.....9



## 1 DESCRIPTION

---

LPC-2.DI6 is used as standard digital input module for eight connections to 24 V DC external sources. Module is galvanic isolated from the rest of the LPC-2 system. It can be used in a wide range of operation where sensors and devices connected to the LPC-2.DI6 module provide 24 V DC signals required for inputs' activation.

LEDs indicate active signal present on each module input (refer to the Table 6).

Module is powered from internal BUS.

NOTE: For proper system configuration and data allocation please refer to LPC Composer software help menu.



## 2 FEATURES

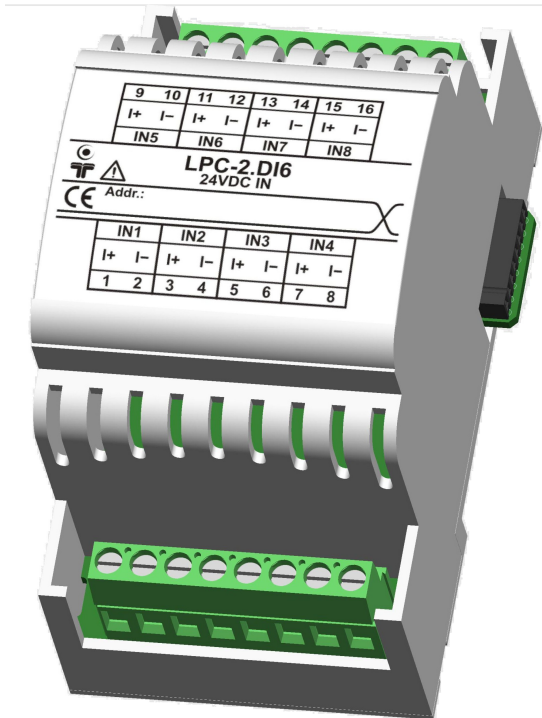

Figure 1: LPC-2.DI6 module.

### Table 1: Technical data

Eight external 24 V DC digital inputs, galvanic isolated

Flexible input for wide use of operation

Standard DIN EN50022-35 rail mounting



### 3 INSTALLATION

#### 3.1 Connection scheme

Figure 2: Connection scheme

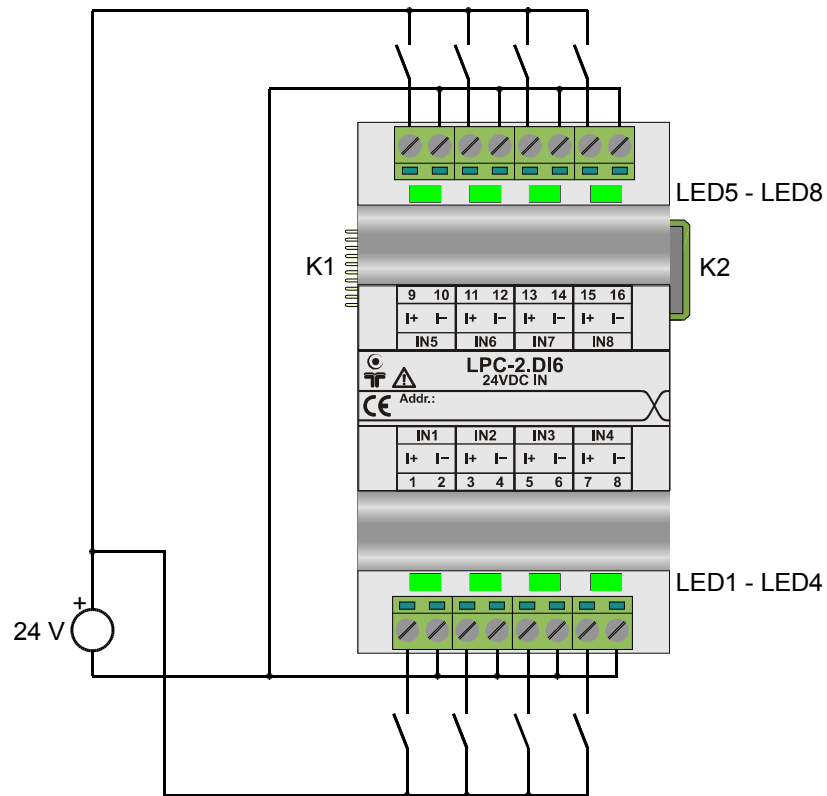

Table 2: IN<sup>1</sup>

|            |   |                       |
|------------|---|-----------------------|
| IN1.1 (I+) | Digital input in reference to IN1.2, 0..24 V DC | 24 V DC digital input |
| IN1.2 (I-) | Reference                                       | Reference to 24 V DC  |
| IN2.3 (I+) | Digital input in reference to IN2.4, 0..24 V DC | 24 V DC digital input |
| IN2.4 (I-) | Reference                                       | Reference to 24 V DC  |
| IN3.5 (I+) | Digital input in reference to IN3.6, 0..24 V DC | 24 V DC digital input |
| IN3.6 (I-) | Reference                                       | Reference to 24 V DC  |
| IN4.7 (I+) | Digital input in reference to IN4.8, 0..24 V DC | 24 V DC digital input |
| IN4.8 (I-) | Reference                                       | Reference to 24 V DC  |

<sup>1</sup> Wires connected to the module must have cross sectional area at least 0.75 mm<sup>2</sup>. Minimum temperature rating of wire insulation must be 85 °C.



**Table 2: IN**

|             |  |                       |
|-------------|--|-----------------------|
| IN5.9 (I+)  | Digital input in reference to IN5.10, 0..24 V DC | 24 V DC digital input |
| IN5.10 (I-) | Reference  | Reference to 24 V DC  |
| IN6.11 (I+) | Digital input in reference to IN6.12, 0..24 V DC | 24 V DC digital input |
| IN6.12 (I-) | Reference  | Reference to 24 V DC  |
| IN7.13 (I+) | Digital input in reference to IN7.14, 0..24 V DC | 24 V DC digital input |
| IN7.14 (I-) | Reference  | Reference to 24 V DC  |
| IN8.15 (I+) | Digital input in reference to IN8.16, 0..24 V DC | 24 V DC digital input |
| IN8.16 (I-) | Reference  | Reference to 24 V DC  |

**Table 3: Digital input specification**

|                 |   |         |
|-----------------|---|---------|
| IN1.1 .. IN8.15 | Digital input reference to IN1.2 up to IN8.16,<br>0 .. 24 V DC<br>$R_{in} = 3.6 \text{ k}\Omega$<br>Off ( $U_{in} < 2 \text{ V DC}$ )<br>On ( $U_{in} > 15 \text{ V DC}$ )<br>Max. input voltage = 35 V DC<br>Max. input frequency = 5 Hz | 24 V DC |
|-----------------|---|---------|

**Table 4: K1**

|              |                        |                          |
|--------------|------------------------|--------------------------|
| Internal BUS | Data & DC power supply | Connection to I/O module |
|--------------|------------------------|--------------------------|

**Table 5: K2**

|              |                        |                          |
|--------------|------------------------|--------------------------|
| Internal BUS | Data & DC power supply | Connection to I/O module |
|--------------|------------------------|--------------------------|

**Table 6: LED1 - LED8**

|        |                     |   |
|--------|---------------------|---|
| Status | Digital input state | On: Input voltage present between IN1.1 and IN1.2 up to IN8.15 and IN8.16<br>Off: Input voltage not present between IN1.1 and IN1.2 up to IN8.15 and IN8.16 |
|--------|---------------------|---|





### 3.2 Mounting instructions

**Figure 3: Housing dimensions**

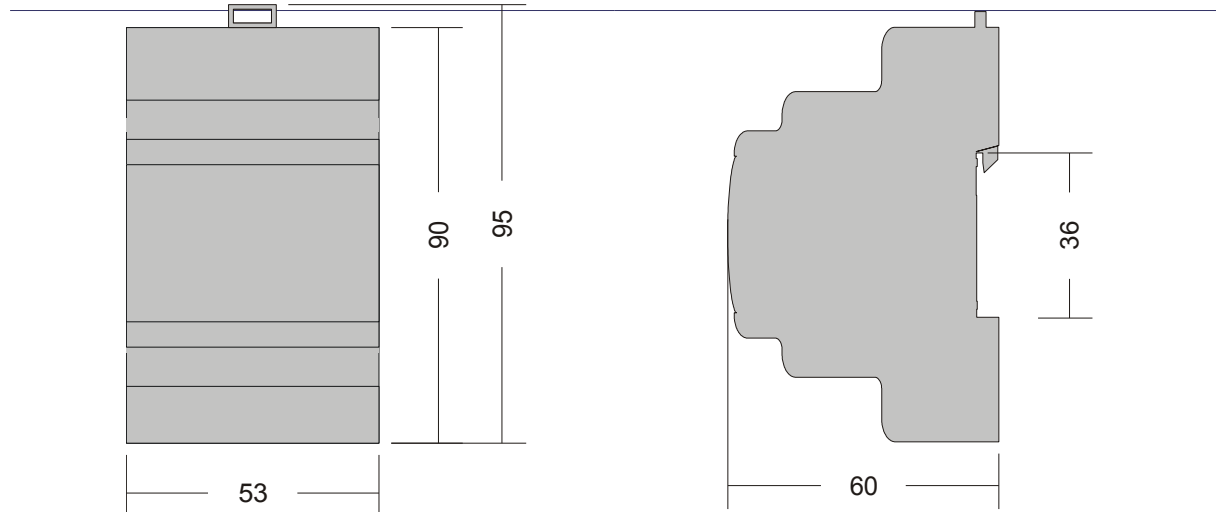

Dimensions in millimeters.



All connections, module attachments and assembling must be done while module is not connected to the main power supply.

#### **Mounting instructions:**

1. Switch OFF main power supply.
2. Mount LPC-2.DI6 module to the provided place inside an electrical panel (DIN EN50022-35 rail mounting).
3. Mount other LPC-2 modules (if required). Mount each module to the DIN rail first, then attach modules together through K1 and K2 connectors.
4. Connect digital inputs' wires according to the connection scheme in Figure 2.
5. Switch ON main power supply.

Dismount in reverse order. For mounting/dismounting modules to/from DIN rail a free space of at least one module must be left on the DIN rail.

NOTE: LPC-2 main module should be powered separately from other electrical appliance connected to LPC-2 system. Signal wires must be installed separately from power and high voltage wires in accordance with general industry electrical installation standard.



### 3.3 Module labeling

**Figure 5: Labels on housing**

Label 1 (MC3 sample):

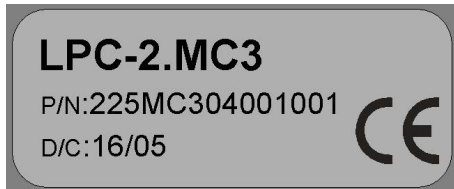

Label 2 (MC3 sample):

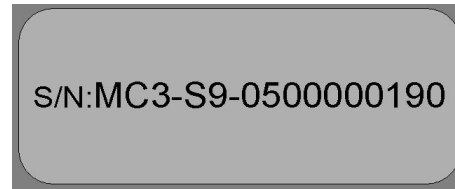

**Label 1 description:**

1. **LPC-2.MC3** is the full product name.
2. **P/N:225MC304001001** is the part number.
  - **225** - general code for product family,
  - **MC3** - short product name,
  - **04001** - sequence code,
    - **04** - year of code opening,
    - **001** - derivation code,
  - **001** - version code (reserved for future HW and/or SW firmware upgrades).
3. **D/C:16/05** is the date code.
  - **16** - week and
  - **05** - year of production.

**Label 2 description:**

1. **S/N:MC3-S9-0500000190** is the serial number.
  - **MC3** - short product name,
  - **S9** - user code (test procedure, e.g. Smarteh person xxx),
  - **0500000190** - year and current stack code,
    - **05** - year (last two cyphers),
    - **00000190** - current stack number; previous module would have the stack number 00000189 and the next one 00000191.



## 4 TECHNICAL SPECIFICATIONS

**Table 6: Technical specifications**

|                                   |  |
|-----------------------------------|--|
| Power supply                      | from internal BUS  |
| Power consumption                 | 0.25 W   |
| Nominal input voltage             | 24 V DC  |
| Max. input voltage                | 35 V DC  |
| Number of digital inputs          | 8  |
| Off / “0” input signal voltage    | $U_{in} < 2 \text{ V DC}$  |
| On / “1” input signal voltage     | $U_{in} > 15 \text{ V DC}$   |
| Connection type                   | screw type connector for stranded wire 0.75 to 2.5 mm <sup>2</sup> |
| Dimensions (L x W x H)            | 90 x 53 x 60 mm  |
| Weight                            | 100 g  |
| Ambient temperature               | 0 to 50 °C   |
| Ambient humidity                  | max. 95 %, no condensation   |
| Transport and storage temperature | -20 to 60 °C   |
| Pollution degree                  | 2  |
| Protection class                  | IP 30  |



## 5 CHANGES

---

The following table describes all the changes to the document.

| Date      | V.  | Description   |
|-----------|-----|---|
| 1.7.2012  | 005 | CGP General update .  |
| 11.5.2010 | 004 | Updated warranty permanence.  |
| 30.6.2005 | 003 | The initial version, issued as <i>LPC-2.DI6 module UserManual</i> . |



## 6 NOTES

---

