



SMARTEH[®]
LIVING SYSTEMS

USER MANUAL

- Additional equipment
LOC-1
Occupancy sensor

Version 1

Written by SMARTEH d.o.o.
Copyright © 2016, SMARTEH d.o.o.

User Manual

Document Version: 1
September, 2016



STANDARDS AND PROVISIONS: Standards, recommendations, regulations and provisions of the country in which the devices will operate, must be considered while planning and setting up electrical devices. Work on 100 .. 230 V AC network is allowed for authorized personnel only.

DANGER WARNINGS: Devices or modules must be protected from moisture, dirt and damage during transport, storing and operation.

WARRANTY CONDITIONS: For all modules LONGO LPC-2 - if no modifications are performed upon and are correctly connected by authorized personnel - in consideration of maximum allowed connecting power, warranty of 24 months is valid from the date of sale to the end buyer, but not more than 36 months after delivery from Smarteh. In case of claims within warranty time, which are based on material malfunctions the producer offers free replacement. The method of return of malfunctioned module, together with description, can be arranged with our authorized representative. Warranty does not include damage due to transport or because of unconsidered corresponding regulations of the country, where the module is installed.

This device must be connected properly by the provided connection scheme in this manual. Misconnections may result in device damage, fire or personal injury.

Hazardous voltage in the device can cause electric shock and may result in personal injury or death.

NEVER SERVICE THIS PRODUCT YOURSELF!

This device must not be installed in the systems critical for life (e.g. medical devices, aircrafts, etc.).

If the device is used in a manner not specified by the manufacturer, the degree of protection provided by the equipment may be impaired.

Waste electrical and electronic equipment (WEEE) must be collected separately!

LONGO LPC-2 complies to the following standards:

- EMC: EN 61000-6-3:2007 + A1:2011, EN 61000-6-1:2007, EN 61000-3-2:2006 + A1:2009 + A2: 2009, EN 61000-3-3:2013
- LVD: IEC 61010-1:2010 (3rd Ed.), IEC 61010-2-201:2013 (1st Ed.)

Smarteh d.o.o. operates a policy of continuous development. Therefore we reserve the right to make changes and improvements to any of the products described in this manual without any prior notice.

MANUFACTURER:

SMARTTEH d.o.o.
Poljubinj 114
5220 Tolmin
Slovenia



Index

Additional equipment LOC-1

- 1 ABBREVIATIONS.....1
- 2 DESCRIPTION.....2
- 3 FEATURES.....3
- 4 INSTALLATION.....4
 - 4.1 Connection scheme.....4
 - 4.2 Mounting instructions.....7
 - 4.3 Module labeling.....9
- 5 TECHNICAL SPECIFICATIONS.....10
- 6 SPARE PARTS.....11
- 7 CHANGES.....12
- 8 NOTES.....13



1 ABBREVIATIONS

Sorted by order of appearance in document:

LED Light emitting diode



2 DESCRIPTION

The LOC-1 is a 4 wire occupancy sensor used in combination with the input modules (e.g., LPC-2.I16, LPC-2.DI1, LPC-2.DI5, LPC-2.R01, LPC-2.R02) to detect moving person or object.

LOC-1 uses PIR sensor for occupancy sensing and current protected bipolar transistor as a switching element.



3 FEATURES



Figure 1: LOC-1 Occupancy sensor

Table 1: Features
Wide power supply range: 5 .. 32 V DC/AC
Output voltage free contact
Mounting with integrated magnets or screws ¹
Convenient enclosure for multi mounting possibilities
2 diagnose LED

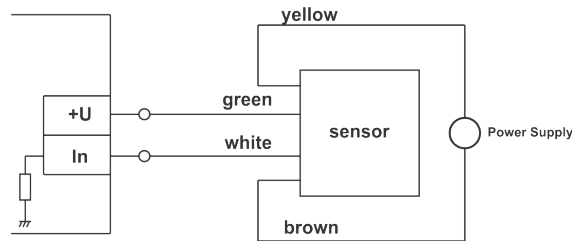
¹ Screws are not supplied with sensor.



4 INSTALLATION

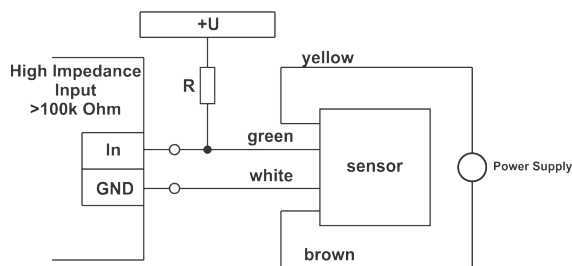
4.1 Connection scheme

Figure 2: Connection scheme with Smarteh modules²



Power Supply = 5 .. 32 V AC/DC

Figure 3: Connection scheme with pull-up resistor

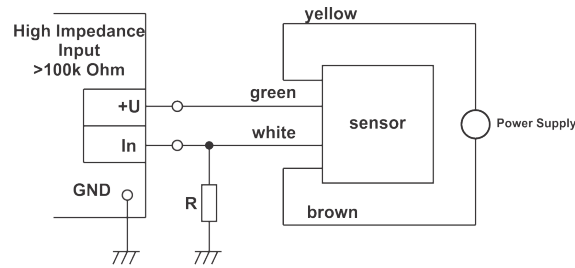


	+U = 10 .. 32 V DC	R = 3 .. 20 kΩ	Power Supply = 5 .. 32 V AC/DC
Option 1:	No moving person or object present: voltage drop on sensor > 95 % Vcc. Moving person or object present: voltage drop on sensor < 2 V.		
	+U = 5 V DC	R = 1 .. 20 kΩ	Power Supply = 5 .. 32 V AC/DC
Option 2:	No moving person or object present: voltage drop on sensor > 4 V. Moving person or object present: voltage drop on sensor < 1 V.		

² Smarteh input modules (e.g., LPC-2.116, LPC-2.D11, LPC-2.DI5, LPC-2.R01, LPC-2.R02).

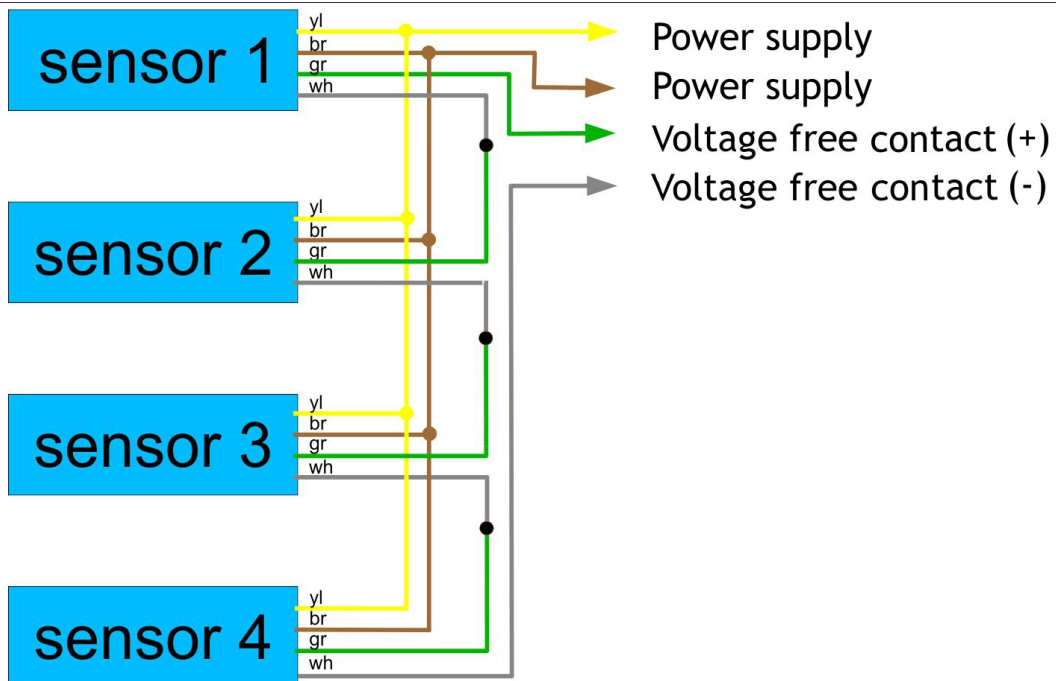
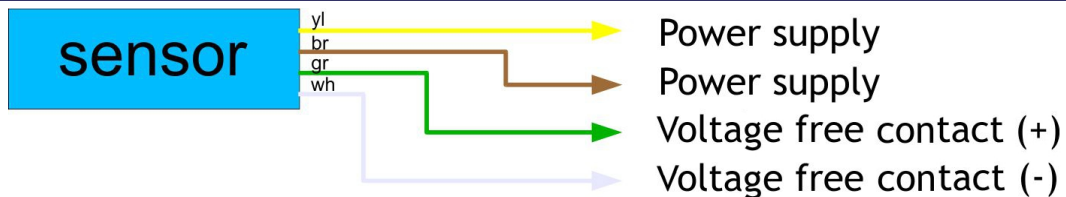


Figure 4: Connection scheme with pull-down resistor



	+U = 10 .. 32 V DC	R = 3 .. 20 kΩ	Power Supply = 5 .. 32 V AC/DC
Option 1:	No moving person or object present: voltage drop on sensor > 95 % Vcc. Moving person or object present: voltage drop on sensor < 2 V.		
	+U = 5 V DC	R = 1 .. 20 kΩ	Power Supply = 5 .. 32 V AC/DC
Option 2:	No moving person or object present: voltage drop on sensor > 4 V. Moving person or object present: voltage drop on sensor < 1 V.		

Figure 5: Connection scheme for single or multiple sensors³



³ Maximum allowed number of multiple sensors is 4.



Figure 6: Connection scheme

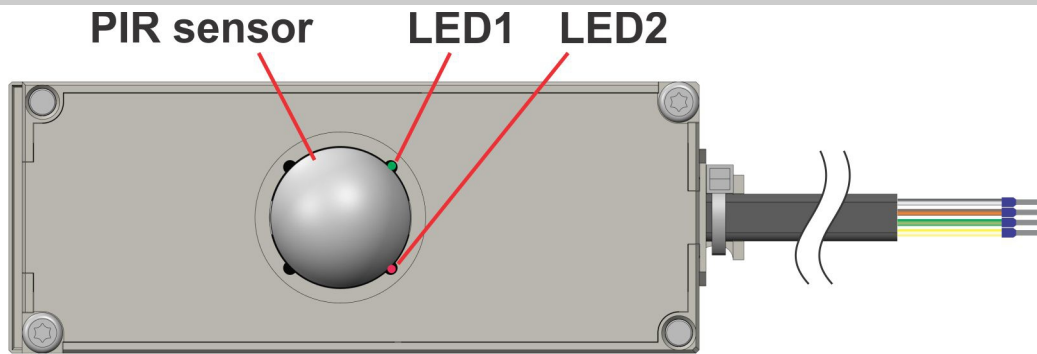


Table 2: Flying lead wires

Yellow	5 .. 32 V AC/DC ⁴	Power supply
Brown	GND	Ground
Green	5 .. 32 V DC (positive)	NO voltage free contact
White	0 V DC (negative)	NO voltage free contact

Table 3: LEDs

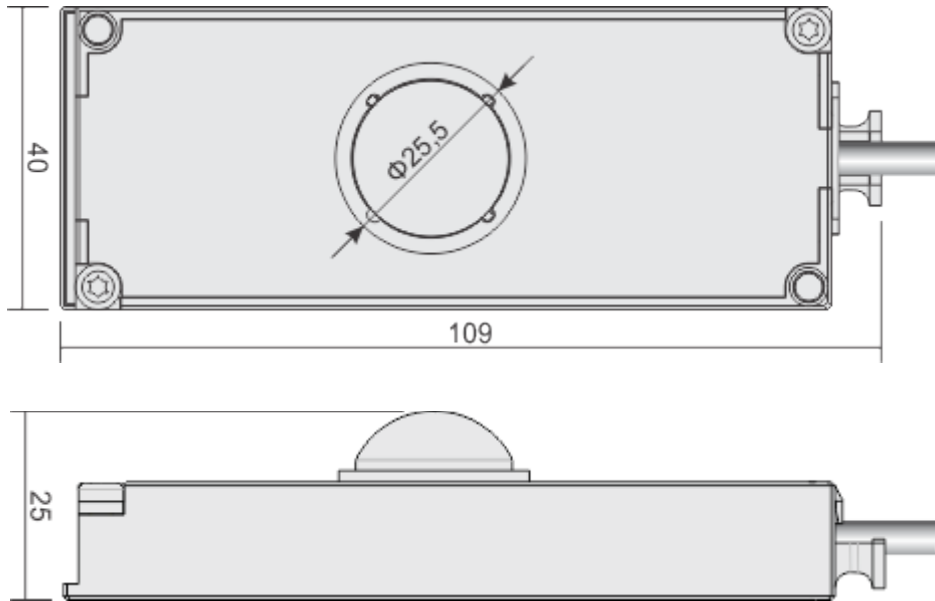
LED1: green	No moving person or object presence indication	ON: no moving person or object present - voltage free contact opened OFF: moving person or object present - voltage free contact closed, power supply missing or power off
LED2: red	Moving person or object presence indication	ON: moving person or object present - voltage free contact closed OFF: no moving person or object present - voltage free contact opened, power supply missing or power off

⁴ In case of 5 .. 10 V DC power supply, use of stabilized power supply is mandatory.



4.2 Mounting instructions

Figure 7: Housing dimensions



Dimensions in millimeters.



All connections, module attachments and assembling must be done while module is not connected to the main power supply.

Mounting instructions:

The occupancy sensor should be located on the position that provides maximum effect.⁵

1. Mount LOC-1 sensor on the position with the magnets or screws⁶. Magnets can be pushed to the other side of abutment surface if needed.
2. Connect wires to input module according to Figure 2, 3 or 4.

⁵ See figure 9.

⁶ Screws are not supplied with sensor.



Figure 8: LOC-1 orientation

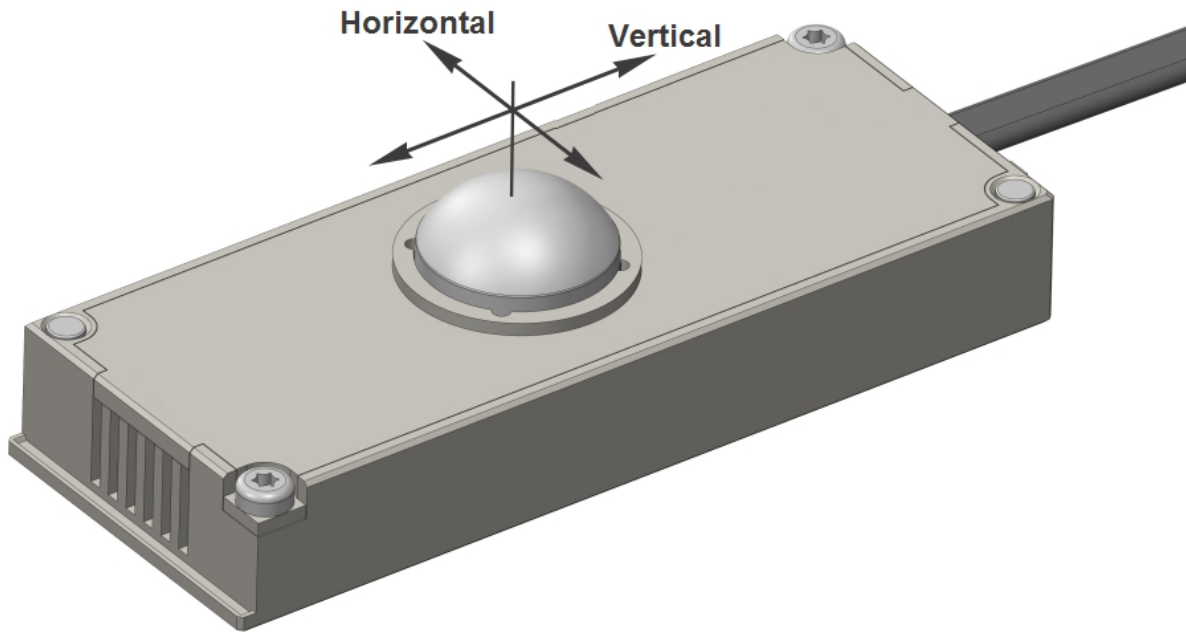
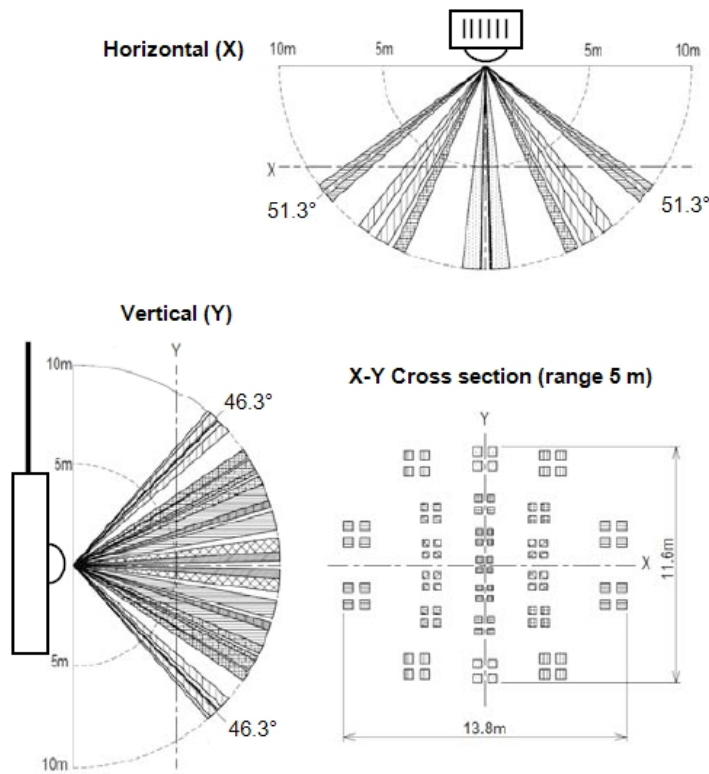


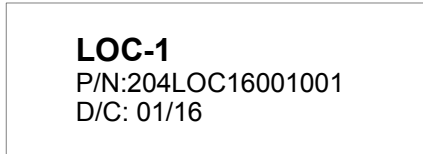
Figure 9: LOC-1 detection area



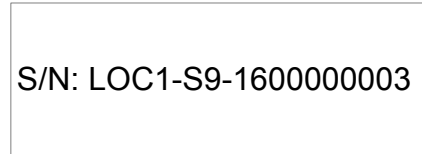
4.3 Module labeling

Figure 10: Labels

Label 1 (sample):



Label 2 (sample):



Label 1 descriptions:

1. **LOC-1** is the full product name.
2. **P/N: 204LOC16001001** is the part number.
 - **204** - general code for product family,
 - **LOC** - short product name,
 - **16001** - sequence code,
 - **16** - year of code opening,
 - **001** - derivation code,
 - **001** - version code (reserved for future HW and/or SW firmware upgrades).
3. **D/C: 01/16** is the date code.
 - **01** - week and
 - **16** - year of production.

Label 2 descriptions:

1. **S/N: LOC1-S9-1600000003** is the serial number.
 - **LOC1** - short product name,
 - **S9** - user code (test procedure, e.g. Smarteh person xxx),
 - **1600000003** - year and current stack code,
 - **16** - year,
 - **00000003** - current stack number; previous module would have the stack number 00000002 and the next one 00000004.



5 TECHNICAL SPECIFICATIONS

Table 4: Technical specifications

Power supply	5 .. 32 V AC/DC ⁷
Consumption	max. 15 mA
Voltage free contact power supply ⁸	5 .. 32 V DC
Output type	transistor (NO)
Output current	max. 15 mA, internally limited
Dimensions (L x W x H)	109 x 40 x 25 mm
Weight	65 g
Wire length connection	2 m
Ambient temperature	0 to 50 °C
Transport and storage temperature	-20 to 60 °C
Detection range	max. 12 m
Detection area	vertical: 92° (± 46°) horizontal: 102° (± 51°) detection zones: 92
Conditions concerning detection	the temperature difference between the moving person or object and the surroundings should be superior to 4 °C (7.2 °F). movement speed: 1.0 m/s target concept is human body (size: 700 x 250 mm)

⁷ In case of 5 .. 10 V DC power supply, use of stabilized power supply is mandatory.

⁸ See figure 2,3 and 4 for wiring scheme.





6 SPARE PARTS

For ordering spare parts following Part Numbers should be used:

LOC-1 Occupancy sensor, 2 m	
LOC-1	P/N: 204LOC16001001





7 CHANGES

The following table describes all the changes to the document.

Date	V.	Description
30.09.16	1	The initial version, issued as LOC-1 <i>User Manual</i> .





Additional equipment LOC-1

8 NOTES

